



By appointment to The Royal Danish Court

morsø

Installation and Operating Instructions

5660 Insert For use in North America



Read this entire manual before you install and use your new room heater. If this room heater is not properly installed, a house fire may result. To reduce the risk of fire, follow the installation instructions. Failure to follow instructions may result in property damage, bodily injury, or even death.

Contact local building officials about restrictions and installation/inspection-requirements in your area.

Save these instructions

MORSØ JERNSTØBERI A/S . DK-7900 NYKØBING MORS
E-Mail: stoves@morsoe.com · Website: www.morsoe.com

Distributed by: **MORSO US LLC**
1011 Highway 52 West - Portland TN - 37148 - USA
Website: www.morsousa.com

We congratulate you on your choice of a Morsø stove. Morsø has been producing some of the world's best stoves since 1853. If you follow this installation- and operating instruction carefully, we can assure you many years of warmth and pleasure.

Optional Accessories

A wide range of accessories (such as handling gloves, fireside tools, glass cleaner and heatproof paint) are available for use with your Morsø stove. They help with day-to-day running and maintenance. Contact your Morsø dealer for more information.

The Morsø 5660 Insert meets the U.S. Environmental Protection Agency's emission limits for wood heaters sold on or after July 1, 1990

The Morsø 5660 Insert have been tested by OMNI-Test Laboratories, Inc. The test standards are UL1482-1998 for the United States and ULC S628 – M93 for Canada.

The stove is listed for burning wood only. Do not burn other fuels.



NATIONAL FIREPLACE INSTITUTE
NFI
CERTIFIED
www.nficertified.org

We suggest that our woodburning hearth products be installed and serviced by professionals who are certified in the U.S. by the National Fireplace Institute® (NFI) as NFI Woodburning Specialists or who are certified in Canada by Wood Energy Technical Training (WETT).



Wood Energy Technical Training
www.wettinc.ca

Cast iron

Cast iron is a live material. There are no two ovens that are identical. This is partly due to the tolerances of the casting process, partly because the ovens are a work of craftsmanship.

CONTENTS:

| | | |
|------------|---|-----------|
| 1.0 | Installation of your Morsø stove | 4 |
| 1.1 | The chimney / flue system | 9 |
| 1.2 | Flue Connection | 10 |
| 1.3 | Connection to existing chimney | 10 |
| 1.4 | Positioning the stove | 12 |
| 1.5 | Installing the blower (option) | 14 |
| 2.0 | Operation | 15 |
| 2.1 | Before you start firing | 15 |
| 2.2 | Lighting and loading intervals | 16 |
| 3.0 | Maintenance | 18 |
| 3.1 | Exterior maintenance | 18 |
| 3.2 | Internal maintenance | 18 |
| 3.3 | Cleaning the Stove and the Flue | 20 |
| 3.4 | Leaving the stove for extended periods | 21 |
| 3.5 | Parts diagram | 22 |
| 3.6 | Parts list | 23 |

1.0 Installation of your Morsø stove

Installation of woodburning stoves must be safe and legal.

If your Morsø stove is not installed correctly, it may cause a house fire. To reduce the risk of fire, the installation instructions must be followed carefully. Contact the local building officials about restrictions and installation inspection in your area.

Before you start installing your stove, make sure that:

- The stove and chimney connection are placed far enough from combustible materials to meet all clearance requirements.
 - The floor protection must be adequate and must be made correctly according to the requirements.
- All necessary approvals are needed from the local building officials.

The data plate, which is located on the back of the stove, provides information regarding safety testing information, name of certified testing laboratory, and installation requirements. Installation requirements vary in different districts, and the local building officials have the final authorization to approve your installation. You should discuss the installation with them before beginning. Please ask your dealer for further information.

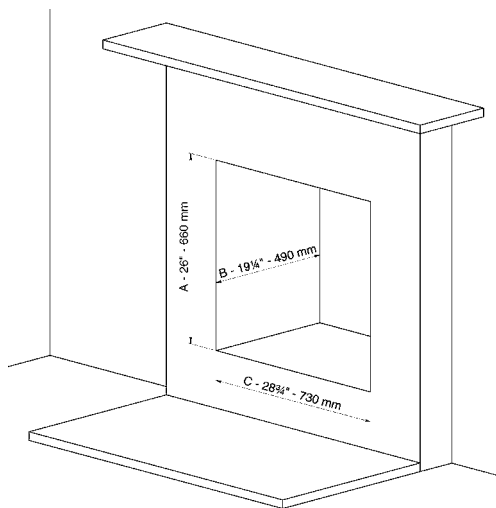

The figure above shows the required fireplace dimension required for the Morsø 5660 insert. It is easier to make adjustments to the masonry surrounding the insert, when the heavy cast iron is not connected to the steel box. Use the steel box as a template for the masonry adjustments. Allow extra room for installation, especially above the insert.

Minimum Masonry fireplace size

| | Height (A) | Depth (B) | Width (C) |
|------------|--------------|---------------|---------------|
| Inches/mm. | 26" / 660 mm | 19¼" / 490 mm | 28¾" / 730 mm |

The stainless steel connector must be at least 8 feet in length.
The chimney must have a clay liner or a stainless steel liner.
Do not move bricks or mortar from the existing fireplace.
Remove or lock existing fireplace dampers in the open position.

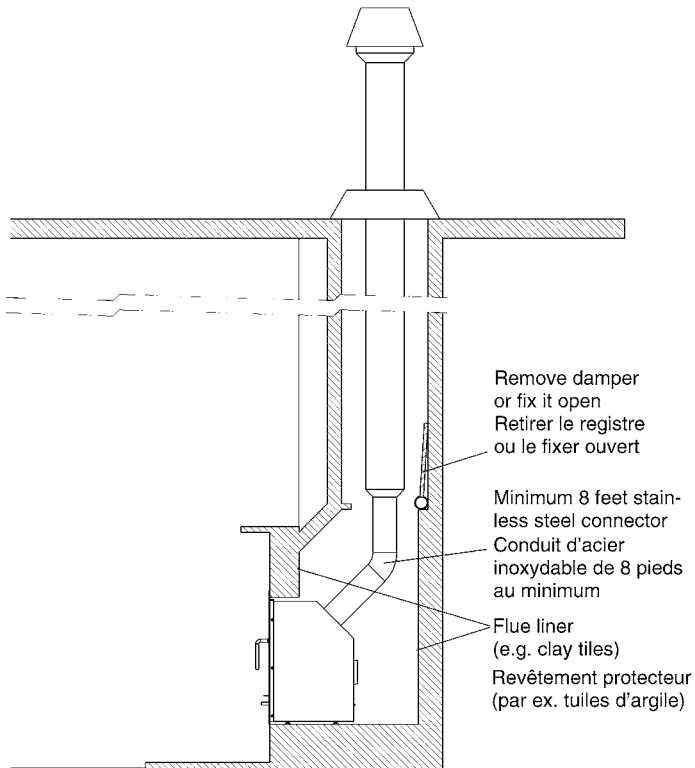

The stainless steel chimney liner (flexible or rigid) is available from most specialty stove retailers. The installation may be used with a factory built or masonry fireplace. Be sure to fulfill all requirements.

Your Morsø 5660 Insert is fully assembled when you receive it. This ensures optimum protection during transport. However, in order to connect the stove to your chimney installation, it is necessary to dismantle the stove's flue collar.

This may only be done by disassembling the baffleplate and take it out of combustion chamber.

The Morsø 5660 weighs 327 lbs. In order to avoid damages when unpacking and installing the stove, it is recommended that two persons carry out this task. Likewise, it is advisable to use an underlay (cardboard, rug, or the like) for placing parts during the installation.



Stove door

Firstly, dismantle the stove door. This will ease the installation and avoid damage. Using the allen key supplied, loosen the allen screws at each hinge pin and lift up the two hinge pins, and dismantle the door.

Note: The brass washer in the upper hinge is loose and must be put in place again when remounting the door.



Fireproof materials

Now take out the fireproof liners and insulation materials from the combustion chamber in the following sequence: Front bottom liner, rear bottom liner, the two side stones, and the two liners at the rear wall. Finally, remove the stone and the insulation mat over the baffle plate of the combustion chamber.



CAUTION: The liners are very porous and must be handled with great care.

Baffle plate/secondary air supply

The baffle plate is mounted with four M8 bolts. The baffle plate is heavy (30 lbs.), and therefore it is difficult to hold it in place over the four threaded holes.

For this reason, two guide bolts without heads are included to facilitate the positioning.

The outermost bolts in each side are unscrewed.



The two guide bolts are now screwed so far into the outermost holes in each side that the ends are barely visible (this is necessary in order to bring the baffle plate down).

Next, the two center bolts are unscrewed.

The baffle plate is now resting on the two guide bolts.

The baffle plate is removed carefully.

Flue collar

The flue collar with the stop bar is unscrewed from the stove.

The flue collar is connected to the flue pipe (8 feet stainless steel connector) or the flexible pipe in your fireplace/chimney.

A fireplace may be constructed in several ways.

If necessary, ask your chimney sweep about the optimum connection between the insert and the existing chimney installation.

The stove is now reassembled in the reverse order of which it was disassembled.

Combustion chamber

Guide the flue pipe with the flue collar mounted on down to the circular hole in the insert box.

The flue collar (now connected to the chimney installation) with the spherical damper is fastened to the combustion chamber.

The baffle plate is mounted over the two guide bolts. Next, the two M8 center bolts are screwed in. The two guide bolts are unscrewed, and the last two M8 bolts are inserted and screwed in.



When the insert has been installed, it can be leveled by means of the adjusting bolts. To access the bolts lift the bottom liner.

Fireboxliners and fireproof materials are put back in place in the following order: the two rear stones, the two side stones, and the two bottom stones. The fireproof insulation mat is carefully put in place on top of the baffle plate. Finally, the last liner is put back in place (in front, centered on the baffle plate and slanted up towards the smoke exit hole). Caution: The liners are very porous and must be handled with great care.

The stove door is repositioned on the hinges with the hinge pins. Remember to put the brass washer back in place on the upper hinge.



1.1 The chimney / flue system

Note that the flue system must be independently secured and must not rely on the stove for support.

The stove must not be connected to a chimney flue serving any other appliance. (Several flues may run up a single chimney stack; use one flueway per appliance).

Use a residential type masonry or listed type HT factory-built chimney.

High Temperature (H.T.) Chimney Standard UL-103-1985 (2100° F.) for the USA, and High Temperature (650°C) Standard ULC S-629 for Canada.

The internal dimensions of the chimney connector and chimney must not be less than 6 inches diameter (or equivalent cross section), and should not be significantly larger than this. Too large a section will tend to allow the flue gases to cool excessively, causing sluggishness or unpredictability in the stove's performance.

We recommend the length of the chimney system should be at least 16 feet (**not required**) above the stove in normal domestic situations, measured from the flue collar to the top of the chimney. Local conditions like for example - roof constructions, large trees nearby and high altitude, may influence the chimney draft and height. Therefore, contact the local professional chimney sweep or your Morsø dealer.

Do not connect to any air distribution duct or system.

Important: If the installation instructions are not followed carefully, it may cause dangerous situations like chimney - and house fires. Follow the instructions carefully and do not deviate from them as it may cause injuries to people or property.

1.2 Flue Connection

The stove is supplied from the factory with a flue collar fitted to the top plate.

The flue collar is from the factory prepared for fitting the enclosed 6 inch adapter.

Use a 24 MSG black or blue chimney connector or listed double wall chimney connector. Refer to local codes and the chimney manufacturer's instructions for precautions required for passing a chimney through a combustible wall or ceiling. Remember to secure the chimney connector with a minimum of three screws to the product and to each adjoining section.

Position the stove and connect to the flue system.

Wear gloves and protective eyewear when drilling, cutting or joining sections of chimney connector.

1.3 Connection to the existing chimney

A Chimney connector is the double-wall or single-wall pipe that connects the stove to the chimney. The chimney itself is the masonry or prefabricated structure that encloses the flue. Chimney connectors are used only to connect the stove to the chimney.

Double-wall connectors must be tested and listed for use with solid-fuel burning appliances. Single-wall connectors should be made of 24 gauge or heavier gauge steel. Do not use galvanized connector; it cannot withstand the high-temperatures that smoke and exhaust gases can reach, and may release toxic fumes under high heat. The connector must be 6 inches (150mm) in diameter.

If possible, do not pass the chimney connector through a combustible wall or ceiling. If passage through a combustible wall is unavoidable, refer to the sections on Wall Pass- Throughs. Do not pass the connector through an attic, a closet or similar concealed space when installing the chimney connectors.

It is important to keep the flue gases moving smoothly in the right direction. Do not vent into a large void at this location; rather form one continuous section all the way up. Use mild bends (e.g. 45° vs. 90°) rather than sharp angles where a change of direction is required. All parts of the venting must be accessible for cleaning purposes.

In horizontal runs of chimney, maintain a distance of 18 inches from the ceiling. Keep it as short and direct as possible, with no more than two 90 degree turns. Slope horizontal runs of connector upward 1/4 inch per foot (20 mm per metre) going from the stove toward the chimney. The recommended maximum length of a horizontal run is 3 feet (1 metre), and the total length should be no longer than 8 feet (2.5 metres).

Information on assembling and installing connectors is provided by the manufacturer's instructions exactly as you assemble the connector and attach it to the stove and chimney.

Be sure the installed stove and chimney connector are correct distances from near by combustible materials. See the clearance paragraph page 12.

Chimney Connector Systems and Clearances from Combustible Walls for Residential Heating Appliances

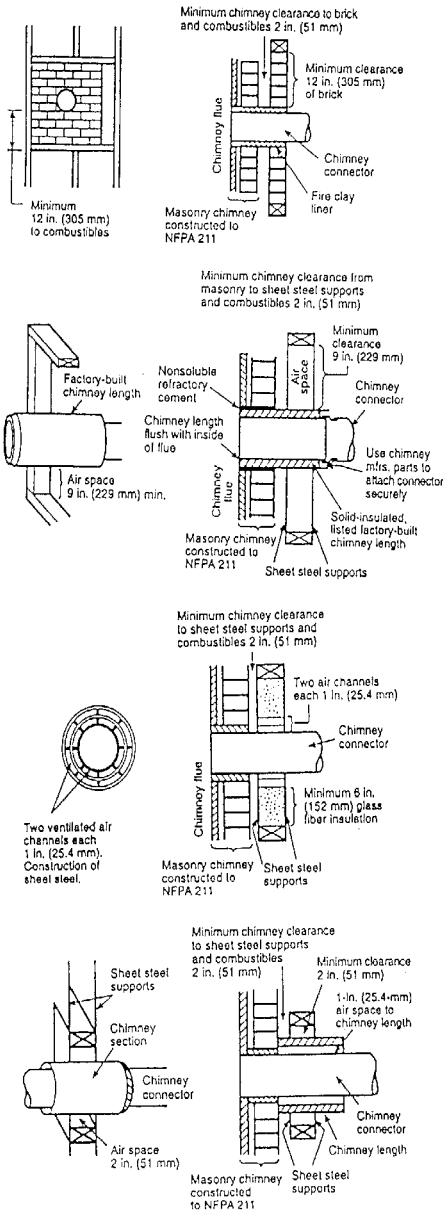

A Minimum 3.5-in thick brick masonry all framed into combustible wall with a minimum of 12-in brick separation from clay liner to combustibles. The fireclay liner shall run from outer surface of brick wall to, but not beyond, the inner surface of chimney flue liner and shall be firmly cemented in place.

B Solid-insulated, listed factory-built chimney length of the same inside diameter as the chimney connector and having 1-in. or more of insulation with a minimum 9-in. air space between the outer wall of the chimney length and combustibles.

C Sheet steel chimney connector, minimum 24 gauge in thickness, with a ventilated thimble, minimum 24 gauge in thickness, having two 1-in. air channels, separated from combustibles by a minimum of 6-in. of glass fiber insulation. Opening shall be covered, and thimble supported with a sheet steel support, minimum 24 gauge in thickness.

D Solid insulated, listed factory-built chimney length with an inside diameter 2-in. larger than the chimney connector and having 1-in. or more of insulation, serving as a pass-through for a single wall sheet steel chimney connector of minimum 24 gauge thickness, with a minimum 2-in. air space between the outer wall of chimney section and combustibles. Minimum length of chimney section shall be 12-in. chimney section spaced 1-in. away from connector using sheet steel support plates on both ends of chimney section. Opening shall be covered, and chimney section supported on both sides with sheet steel supports securely fastened to wall surfaces of minimum 24 gauge thickness. Fasteners used to secure chimney section shall not penetrate chimney flue liner.

1.4 Positioning the stove

CLEARANCE REQUIREMENTS TO COMBUSTIBLE SURFACES

The Morsø 5660 NA is approved in the US and Canada for installation into the following;

1. A masonry fireplace.
2. Morsø Fireplace Insert Zero Clearance Enclosure (separate installations instructions apply).

| | |
|---|------------------------------|
| A | Sidewall to insert |
| B | Combustible mantel to insert |
| C | Side facing |
| D | Hearth extension |
| E | Top facing |

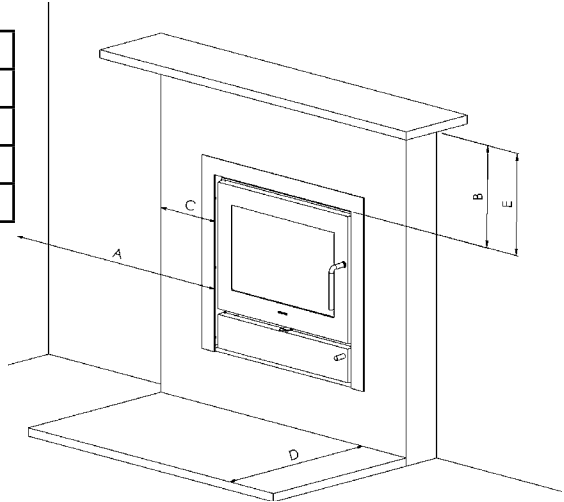

| INSTALLATION | A | B | C | D | E |
|---------------|--------|--------|--------|----------|--------|
| UNITED STATES | 17" | 26½" | 8" | See text | 26½" |
| CANADA | 432 mm | 724 mm | 200 mm | below* | 724 mm |

*

When the appliance is elevated 6" (152 mm in Canada) or more above a combustible floor (as measured from the floor to the bottom of the door glass), the floor in front of the fireplace requires thermal protection equal to R-value =1.79 ft² °F h / BTU. Floor protection must extend out minimum 21" (535 mm in Canada) and 8" (200mm in Canada) to each side of the fuel loading door

When the appliance is elevated 20.25" (515mm in Canada) or more above a combustible floor (as measured from the floor to the bottom of the door glass), the floor in front of the fireplace requires non-combustible ember protection. Floor protection must extend out minimum of 16" (450 mm in Canada) and 8" (200 mm in Canada) to each side of the fuel loading door

The hearth requirements are summed up in the following table.

Floor protection requirements

| | | |
|---|---------------------------------|------------------------------|
| Distance from floor to the bottom of the door glass | Greater than 6" (152 mm) | Greater than 20,25" (515 mm) |
| Hearth extension in front of fuel loading door | 21" (535 mm) | 16" (US) 450 mm (CANADA) |
| Hearth extension to the side of fuel loading door | 8" (US) 200 mm (CANADA) | 8" (US) 200 mm (CANADA) |
| Hearth material or R-value for hearth material | 1.79 ft ² °F h / BTU | Non-combustible material |

Do NOT install in a mobile home

Distance to furniture

The recommended minimum distance from stove to furniture is 42 inches. Note that some furniture is more easily affected by heat and may need to be moved to a greater distance. This is your responsibility.

In addition other combustible materials, away from the stove. In general, a distance of 42 inches must be maintained between the stove and moveable combustible item such as drying clothes, newspapers, firewood etc.

Note:

Acid Protection

If acid-washing the masonry around the stove, protect the stove surface with an acid-proof cover

Fresh Air Inlet

Unless there is deemed to be insufficient residual air into the room via doorways, windows and the like, a dedicated fresh air inlet will be needed. This inlet should have 2 square inches (1250 square mm) of free air space. This is particularly important where the room is well sealed, or where an extractor hood or ventilation system disturbs the natural air pressure. Such an inlet should not be on a wall that is usually subject to negative pressure from normal wind pattern. Avoid placing the inlet directly across the room from the stove, thus causing a cold air draft.

1.5 Installing the Optional Blower Kit

Blower kit contents:

- Thermostat-controlled blower unit
- Speed controller
- Cable ties to fix cord
- Magnetic thermostat sensor

The installation of the blower unit can easily be achieved without the need to remove the insert.

Installing the blower unit (fig A):

The blower unit sits inside the blower housing at the base of the convection box situated behind the front access door under the main firebox.

The blower unit (1) should be placed on the base of the convection chamber and to the rear. It should be centered between the two rectangular ventilation holes (2) in the base.

A series of magnets (6) attached to the base and rear wall of the blower unit are used to secure the blower unit to the base and back wall of the convection chamber. The mouth of the fan unit **MUST** face upwards.

Attaching the Thermostat Sensor

The thermostat sensor is a heat activated device that allows the blower to operate when the stove reaches the required running temperature. The thermostat sensor magnetically attaches to the heat shield positioned at the roof of the blower housing (i.e. the underside of the firebox).

Securing the Power Cord

The power cord can exit the blower chamber either from the left or the right side through cut-outs (7) provided in the side walls of the convection box. The power cord should be secured in place using the cable ties (4) supplied. Additional securing points (8) are provided to the front left and right sides of the blower housing door and should be utilized as a final fixed point for the cord prior to final exit.

Attaching the Speed Controller:

The speed controller is attached across the ventilation grill at the front right of the blower housing base using two hex-head bolts supplied.

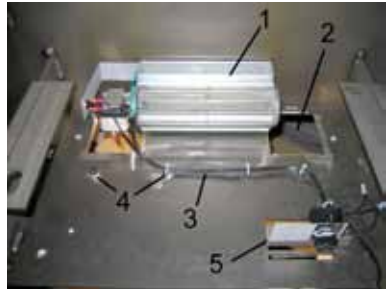
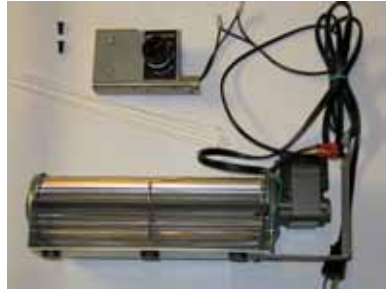

(Fig. A)



2.0 Operation

2.1 Before you start firing

For Use with Solid Wood Fuel Only. Do Not Overfire, If Heater or Chimney Connector Glows You Are Overfiring. Inspect and Clean Chimney Frequently. Under Certain Conditions of creosote buildup may occur. To reduce the risk of smoke and flame spillage, operate only with door fully closed.

Caution:

Hot while in operation. Keep children, clothing and furniture away. Contact may cause skin burns.

Do not use chemicals or fluids to start the fire.

Do not burn garbage or flammable fluids.

Do not use gasoline, gasoline-type lantern fuel, kerosene, charcoal lighter or fluid or similar liquids to start or freshen up a fire in this heater. Keep all such liquids away from the heater while it is in use.

Choosing your fuel

All types of natural wood can be burned on your stove, but they must be well-seasoned and dry. Once the wood is cut to length, it should be split down middle - to suit the dimensions given below - to allow moisture to evaporate.

Cut the wood to a length of max 21 inches (53 cm) and approx. 3 to 3.5 inches (7-8 cm) in section. If you can weigh your wood, aim for around 2 lbs. For correct combustion and heat output, wood fuel should contain no more than 20% moisture; this can easily be checked by using the Morsø Moisture Meter (part # 62929900)

To naturally season wood fuel, stack and store it under cover in an airy location where fresh air can move through each piece. Some soft woods may take as little as one good summer to season whereas harder woods such as oak, maple, and elm may require seasoning up to 18 months. Avoid overly dry wood that is gray in color as under certain conditions it can cause performance problems, such as back-puffing and sluggishness. Well seasoned wood will be light to hold and will show signs of cracking from the center-out in the ends. If your wood spits or sizzles when burnt, and your stove's door glass persistently mists up, your wood is not properly seasoned. Never use drift wood (from the sea), whose salt content may cause corrosion, nor construction wood that may have been impregnated with chemicals.

Starting the first fire

The initial fire should be small, so that the stove paint can cure and the main plates of the stove can settle into position. Some fumes will be given off by the paint. Ventilate the room during this phase.

The setting of the air control lever, lighting techniques and loading intervals will depend on chimney draft, the fuel used, the heat required and so on. Some basic techniques are outlined below.

In principle

Your stove has three air supplies:

Primary air is controlled by the air controller beneath the door. The air from here passes through internal channels and eventually washes at high speed down the back face of the door glass. This super-heated air helps with the combustion of volatile gases produced by the fire.

Secondary air is supplied to the top of the fire through holes in the tubes under the lower baffle. This effectively burns off other residual gases, making for very clean emissions. This air supply is constant and cannot be varied.

Pilot air is supplied to the firebed through a hole placed behind the front grate. This air will activate the embers. This air supply is factory set and cannot be varied.

2.2 Lighting and loading intervals

When first lighting the stove, a large volume of air is needed. When the stove is cold, you should leave the door open an inch or two for the first few minutes and open the primary air supply completely. While the door is open, do not leave the stove unattended.

To establish a reasonable bed of ash on the firebox floor, you should use 5-6 inches thickness (4-6 pound) of dry kindling at the initial lighting. Always maintain a 1-1,5 inch (2-3 cm) layer of ash on the floor of the combustion chamber at all other times.

1. A layer of embers will form rapidly if the stove is lit with fire lighters or 7-10 rolled up sheets of newspaper, underneath roughly 4-5 lb. of dry kindling.
2. Light the fire.
3. Fully open the air controller so that primary air can enter the firebox.
4. After the paper/fire lighters have caught fire, leave the fire door ajar about 1 inch, so that the chimney draws well.
5. After 5-10 minutes the chimney draft should be established, at this point close the fire door. If all the necessary conditions are met, a nice layer of embers will start to accumulate after another 15-20 minutes.
6. Refuelling of your stove should be done while there are still glowing embers in the bed. Spread the embers across the bottom, but concentrated mostly towards the front of the stove.
7. Place 2-3 pieces of fuel weighing roughly 4-6 lb. across the embers in one layer, with spacing of roughly 1 inch between the pieces of wood.
8. When the primary air supply is open all the way and the door is closed, the new fuel will ignite in a few minutes.
9. Once the new fuel has taken, adjust the primary air amount to the desired setting; optimal combustion will continue until glowing embers are produced.
10. A new charge of wood can be added by repeating steps 6 & 7.

Do not for any reason attempt to increase the firing of your heater by altering the air control adjustment range outlined in these directions.

Warning: Fireplace stoves must never be left unattended with doors open.

If the door is left partly open, gas and flame may be drawn out of the fireplace stove opening, creating risks from both fire and smoke. We recommend you to fit a smoke detector in the room where the stove is installed.

DO NOT OVERFIRE THIS HEATER. Overfiring may cause a house fire, or can result in permanent damage to the stove. If any part of the stove glows, you are overfiring.

The maximum recommended weight of wood fuel per load is 2.5 kg/h/5.5lbs (approx 3 split logs).

Under normal firing, the average flue temperature in the stove pipe, measured 20 cm above the stove, is approx. 300° C (550°F). The maximum flue temperature in the stove pipe must not exceed 450° C (750°F). If the flue temperature exceeds 450°C (750°F), it is considered as over firing and may cause premature wear and tear of the stove.

To help gauge the correct running temperature of your stove, we recommend you use the Morsø Flue Gas Thermometer (part # 62901200). The Flue Gas Thermometer magnetically attaches onto the stove pipe approx 20 cm (8") above the stove's top plate and measures the surface temperature of the stove pipe. Please see your authorized Morsø Dealer for availability.

Draft conditions

If smoke or fumes come out of your stove when lightning up and reloading, or if the fire simply will not respond, a poor draft is almost certainly to blame. (In a very few cases, there may be insufficient fresh air getting into the room - see installation advice above). Take advice from your stove supplier on how best to upgrade your flue system to improve draft.

Rules of woodburning

If you want less heat, put fewer logs on the stove and reduce the amount of air. It is still important to maintain a good layer of embers.

Less heat - less wood - less air

Greater heat - more wood - more air

Soot deposits will settle on the glass if the stove is run too slowly or if your wood is not well seasoned.

3.0 MAINTENANCE

When performing maintenance on your stove, always protect yourself, using safety goggles and gloves.

3.1 Exterior Maintenance

The stove surface is painted with heat-resistant Senotherm paint. It is best kept clean by vacuuming with a soft brush attachment or by wiping with a lint-free cloth.

Over a period of time, the painted surface may become slightly grey. A can of Morsø touch-up spray paint should be available from your stove supplier. This can be applied - in accordance with the instructions - in just a few minutes. When first firing after touching up, the stove will give off a slight smell as the paint cures. Make sure to ventilate the room well during this phase.

3.2 Internal maintenance

Glass

If the stove is generally run at the correct temperatures, there should be little or no dirt on the glass. If dirt does settle during lighting, most will burn off as temperatures increase. For heavier deposits that will not burn off, use morsø glass cleaner, applied when the glass is cold, in accordance with the instructions. Never use abrasive cleaners on the glass surface.

Reasons for dirty glass

- Fuel too wet
- Logs too large or not split
- Combustion temperatures too low

Replace broken glass immediately.

Do not operate your stove if the glass in the door is damaged.

If you need to replace the glass, it should be replaced with the high temperature ceramic glass supplied by Morsø, contact your Morsø dealer.

Installing the glass

Never install the glass when the stove is in function.

Ceramic glass replacement

Ceramic glass cannot be recycled because it has a higher melting point than ordinary glass. If ceramic glass is mixed with ordinary glass, the raw material is spoiled, and the reclaiming process may be halted. Take care that the ovenproof glass does not end up among ordinary recycled waste. That will be a great benefit to the environment.

Note: Should be handed in to a recycling station as ceramic glass.

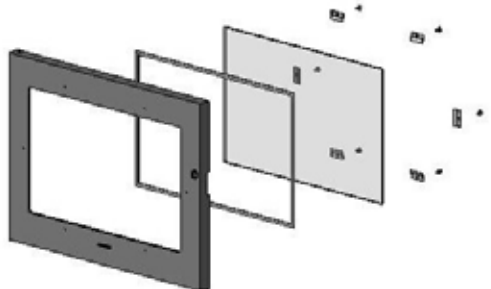

1. Detatch the door (See page 6) off its hinges an place face-down on a sheet of cardboards or other nonabrasive fabric.
2. Unscrew the six bolts that secure the glass. (In the event that a bolt sheers off when being unscrewed, remove the remaining body of the bolt by drilling down its center with 1/8 inch high speed steel drill bit. Smaller drill bits may be successful, but do not use a larger bit. Make sure the bit stays away from the edges of the bolt - this may damage the thread in the cast iron.
3. Remove the old ceramic gaskets and clean up the surface underneath with wire wool or emery paper to remove loose particles.
4. Place the new gasket material in position around the perimeter of the window area, making sure to pinch them to the length in such a way that they make a continuous seal. Leave no gaps.
5. Place the new glass in position on the strips and screw home the fresh bolts and fitting by hand.
6. Finally, give each of the bolts an extra half turn or so. The glass should held tight enough by that cleaning will not dislodge it. Do not over-tighten the bolts as this may put excessive pressure on the glass, resulting in cracking - important!

To reduce the risk of breaking the glass, avoid striking the glass or slamming the door.

Internal service parts

The flame-path equipment - consisting of firebricks, glass, baffle, pilot air assembly and flue collar - are subject to the extremes of heat produced by the fire. From time to time, one or other of these parts may need replacing as a matter of routine maintenance.

NOTE: The flame-path equipment, the ceramic rope and the paint finish are not covered by guarantee.

All of these service parts can be bought from your morsø dealer, and we recommend that damaged parts are replaced as soon as possible to avoid collateral damage.

Should the baffle be distorted by an overfire, the stove will still function, although its efficiency may be compromised. Replace it as soon as possible. Remove the baffle, scrape out the old fire cement and replace with new to make an effective seal.

Reasons for fast internal wear and tear

Persistent heavy firing
Soot and ashes left to accumulate

Rope Gasket

The rope gasket around the perimeter of the door may harden over a period of time. It should be replaced if it becomes difficult to close the door or if air starts to leak in around the perimeter of the door, causing the fire to become a little less controllable. A morsø rope gasket kit is available from your stove supplier.

3.3 Cleaning the Stove and the Flue

Check for soot above the baffle plate and around the flue outlet every month or so to start with. If the stove suddenly becomes sluggish, check for a soot fall around the flue collar or in the flue/chimney. Inspect every month.

Clean the flue/chimney - all the way from the stove and through the flue terminal point above the house.

A good routine is to clean the flue after each heating season in any case, and inspect prior to the season to ensure that bird's nests or other blockages have not occurred during the off season.

Ash disposal

Remove excess ash from the stove bottom on a daily basis or as needed. Ash allowed to build up to the underside of the front grate will trap heat and could cause premature failure of the grate/pilot air assembly.

Caution:

Never empty a stove whilst in operation.

Never use your household or shop vacuum cleaner to remove ash from the stove; always remove and dispose of the ash properly.

Creosote - formation and need for removal

When wood is burned slowly, it produces tar and other organic vapors, which combine with expelled moisture to form creosote. The creosote vapors condense in the relatively cool chimney flue of a slow-burning fire. As a result, creosote residue accumulates on the flue lining. When ignited this creosote makes an extremely hot fire. When burning wood, inspect the chimney connector periodically to determine if a creosote buildup has occurred.

Chimney sweeping

Inspect the system regularly during the heating season as part of a regular maintenance schedule. To inspect the chimney, let the stove cool completely. Then, using a mirror, sight up through the flue collar into the chimney flue. If you cannot inspect the flue system in this fashion, the stove must be disconnected to provide better viewing access.

Clean the chimney using a brush the same size and shape as the flue liner. Run the brush up and down the liner, causing any deposits to fall to the bottom of the chimney where they can be removed through the clean-out door.

Clean the chimney connector by disconnecting the sections, taking them outside, and removing any deposits with a stiff wire brush. Reinstall the connector sections after cleaning, making sure to secure the joints between individual sections with sheet metal screws.

If you cannot inspect or clean the chimney yourself, contact your local professional chimney sweep or local Morsø Dealer.

If you do experience a chimney fire, act promptly and:

Close the air control.

Get everyone out of the house.

Call the Fire Department.

Annual maintenance

Before the heating season, perform a thorough cleaning, inspection and repair:

Thoroughly clean the chimney and chimney connector.

Inspect the chimney for damage and deterioration. Replace weak sections of prefabricated chimney. Have a mason make repairs to a masonry chimney.

Inspect the chimney connector and replace any damaged sections.

Check gasketing for wear or compression, and replace if necessary.

Check the glass for cracking; replace if needed.

Check door and handles for tightness. Adjust if needed.

3.4 Leaving the stove for extended periods

Important:

If the stove is to be left unused for any period of time, clean it out thoroughly and leave the handle for primary air inlet slightly open to allow airflow. Make sure that the flue does not allow rainwater to come anywhere near the stove; install a chimney cap, but do not block off the flue completely.

These measures should ensure there is a slight movement of air through the stove, and that the body of the stove remains dry, right into the corners.

Any ash left within an unfired stove can attract moisture like blotting paper. If moisture is allowed to settle within the stove, rust will form. Rust expands as it takes a grip. This can lead to undue pressure on the stove joints, and this in turn may result in damage to the stove.

NOTE: It is best to thoroughly clean the stove after the heating season has concluded. Adding a dessicant, such as kitty litter, into the stove bottom helps absorb moisture during the summer months. Be sure to remove this prior to the heating season.

Thank you for buying a morsø stove.

We hope you have many years of carefree warmth in its company. Some initial experimentation with loading and running techniques will decide your normal routine. If you have any problems after this short learning phase, please refer to your stove dealer. Should they be unable to help for any reason, please contact us in writing at the address on the front of this publication.

3.5 Parts diagram for the model Morsø 5660 Insert

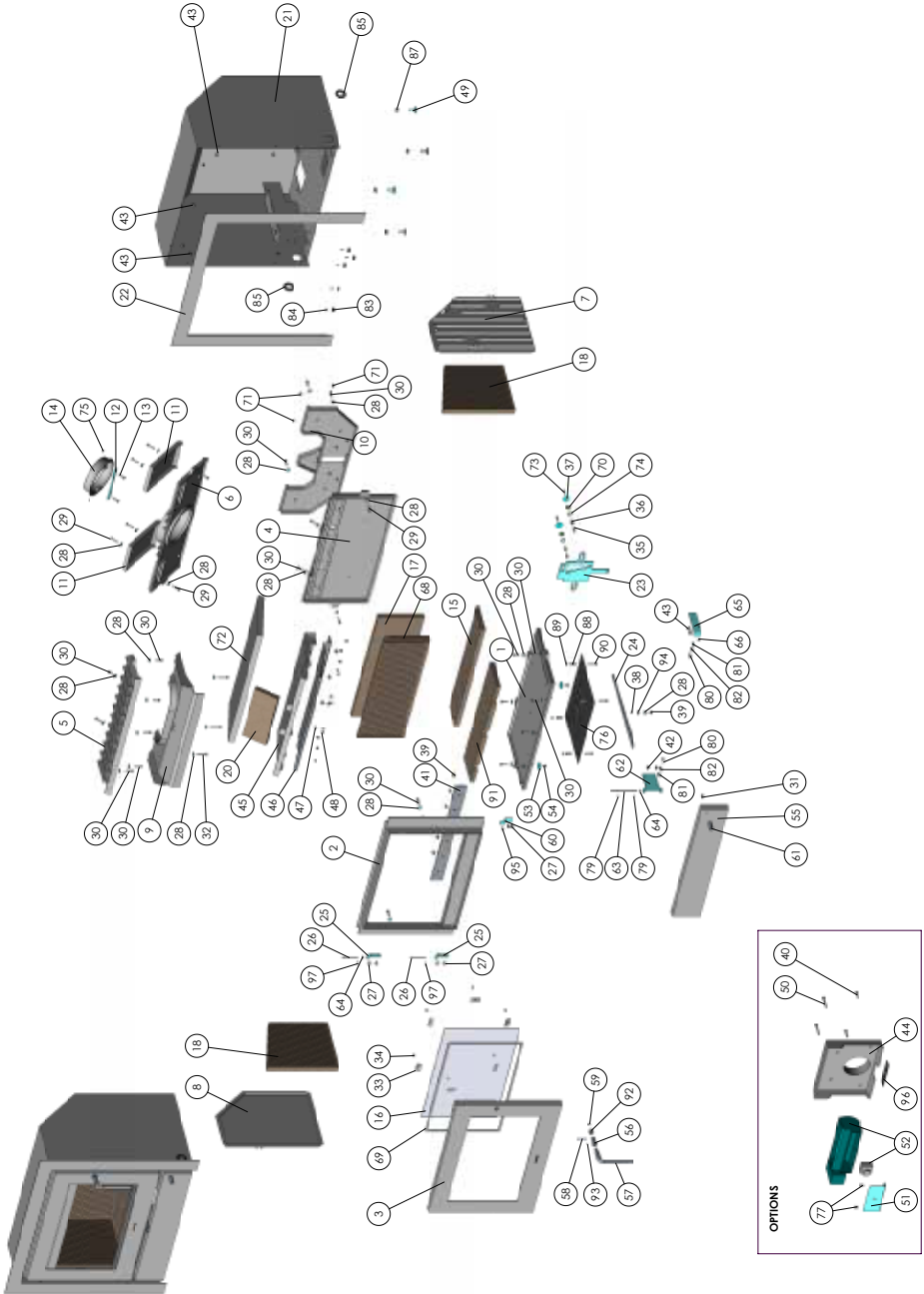

3.6 Parts list for the model Morsø 5660 Insert

| Pos. No. | Description | Itemno. |
|----------|-----------------------------|----------|
| 1 | Bottom plate 5600 | 44560121 |
| 2 | Front frame 5600 | 44560221 |
| 3 | Door 5600 | 44560321 |
| 4 | Rear plate 5600 | 44560400 |
| 5 | Top plate 5600 | 44560521 |
| 6 | Top plate Inclined 5600 | 44560800 |
| 7 | Side plate right 5600 | 34560600 |
| 8 | Side plate left 5600 | 34560700 |
| 9 | Air Canal Top inside 5600 | 34560900 |
| 10 | Air Canal Rear 5600 | 44561000 |
| 11 | Air Canal Inclined 5600 | 34561100 |
| 12 | Stop bar 5600 | 71561100 |
| 13 | Screw | - |
| 14 | Flue collar | 44344721 |
| 15 | Liner Bottom 5600 NA | 79560500 |
| 16 | Glass 5600 | 79560100 |
| 17 | Liner back 5600 NA | 79560800 |
| 18 | Liner side right - NA | 79560900 |
| 19 | - | - |
| 20 | Vertical baffle plate | 79560700 |
| 21 | Insert box 5600 NA | 71561521 |
| 22 | Insert Frame 5600 NA | 71561621 |
| 23 | Secondary draft control | 71560500 |
| 24 | Handle sek. draught control | 71560600 |
| 25 | Door fitting | 71810100 |
| 26 | Hinge pin | 74701000 |
| 27 | Screw | - |
| 28 | Washer | - |
| 29 | Screw | - |
| 30 | Screw | - |
| 31 | Screw | - |
| 32 | Screw | - |
| 33 | Glass fitting | 54146361 |
| 34 | Screw | - |
| 35 | Distance tube | 71562600 |
| 36 | Distance tube | 71562700 |
| 37 | Washer | - |
| 38 | Distance tube | 54202500 |
| 39 | Screw | - |
| 40 | Screw | - |
| 41 | Cover f. Pilot air 5600 | 71561000 |
| 42 | Screw | - |
| 43 | Screw | - |
| 44 | Airtight Canal 5600 | 34561200 |
| 45 | Baffle plate 5600 | 44561400 |
| 46 | Baffle plate, stainless | 71561300 |
| 47 | Screw | - |
| 48 | Screw | - |
| 49 | Adjustment base 5600 | 71560700 |

3.6 Parts list for the model Morsø 5660 Insert

| Pos. No. | Description | Itemno. |
|----------|--------------------------------|----------|
| 50 | Screw | - |
| 51 | Mounting plate Blower | 71563100 |
| 52 | Blower | 54560100 |
| 53 | Washer | - |
| 54 | Screw | - |
| 55 | Front cover 5600 NA | 44561321 |
| 56 | Axis for handle | 71562061 |
| 57 | Door handle, stainless steel | 75263600 |
| 58 | Hinge pin | 541082 |
| 59 | Screw | - |
| 60 | Closing plate | 71562100 |
| 61 | Knob front cover | 71562200 |
| 62 | Front Cover Fitting | 71562300 |
| 63 | Hinge pin | 54502900 |
| 64 | Washer | - |
| 65 | Magnet fitting | 71562400 |
| 66 | Magnet | 79082003 |
| 68 | Liner back 5600 EN + NA | 79560200 |
| 69 | Adhesive fibre for door glass | 79074500 |
| 70 | Spring | 79049100 |
| 71 | Screw | - |
| 72 | Insulation | 79561300 |
| 73 | Screw | - |
| 74 | Washer | - |
| 75 | Screw | - |
| 76 | Radiation Shield Base | 71563000 |
| 77 | Screw | - |
| 79 | Lock ring | 791824 |
| 80 | Screw | - |
| 81 | Cable relief, iron | 76560400 |
| 82 | Cable relief, plastic | 76560500 |
| 83 | Armature for cable relief | 76560200 |
| 84 | Tubular rivet | 74700400 |
| 85 | Nipple | 76560100 |
| 86 | Cable tie | 76560300 |
| 87 | Locking nut | 745010 |
| 88 | Distance tube | - |
| 89 | Washer | - |
| 90 | Screw | - |
| 91 | Front Vermiculite Bottom Plate | 79561600 |
| 92 | Spring for Handle | 79048800 |
| 93 | Hinge pin | 74201900 |
| 94 | Washer | - |
| 95 | Screw | - |
| 96 | Cover plate for air tight | 73563300 |
| 97 | Split pin | 73530700 |