

Jøtul F 118
Manual Version P05

Jøtul F 118

for USA and Canada

Installation and Operating Instructions



Keep these instructions for future reference.

Table of Contents

Accessories	3	
Standards and Safety Notices		
Standards / Codes	4	
Safety Notices	5	
1.0 Installation		
1.1 Assembly Before Installation	5	
1.2 Flue Collar Installation	5	
1.3 Remove Air Control Limit Bolt	5	
1.4 Bottom Heat Shield Installation	6	
1.5 Heat Shield Installation	6	
1.6 Assemble the Door and Control Knobs	6	
1.7 Chimney Connector	6	
2.0 Chimney Requirements		
2.1 Masonry Chimneys	7	
2.2 Prefabricated Chimneys	8	
2.3 Chimney Height	8	
2.4 Wall Pass-Throughs	8	
3.0 Connecting to the Chimney		
3.1 Masonry Chimneys	9	
3.2 Hearthmount into a Masonry Fireplace	9	
3.3 Prefabricated Chimneys	10	
4.0 Clearances to Combustibles		
4.1 Floor Protection	10	
4.2 Clearances to Walls and Ceilings	11	
4.3 Using Shields to Reduce Clearances	11	
4.4 Alcove Installation	11	
Clearance Specifications	12	
Clearance Diagrams	13	
5.0 Operation		
5.1 Use Solid Wood Fuel Only	14	
5.2 How your Jøtul F 118 works	14	
5.3 Controls on the Jøtul F 118	14	
5.4 Break-in Procedure	15	
5.5 Starting and Maintaining a Fire	15	
5.6 Adding Fuel	15	
5.7 Open Door Fire-viewing	16	
5.8 Ash Removal	16	
6.0 Maintenance		
6.1 Glass Care	17	
6.2 Glass Removal or Replacement	17	
6.3 General Care	17	
6.4 Gaskets	17	
6.5 Gasket Replacement	17	
6.6 Chimney System	17	
7.0 Jøtul N. A. wood-burning product limited warranty		21
Illustrated Parts List	19-20	

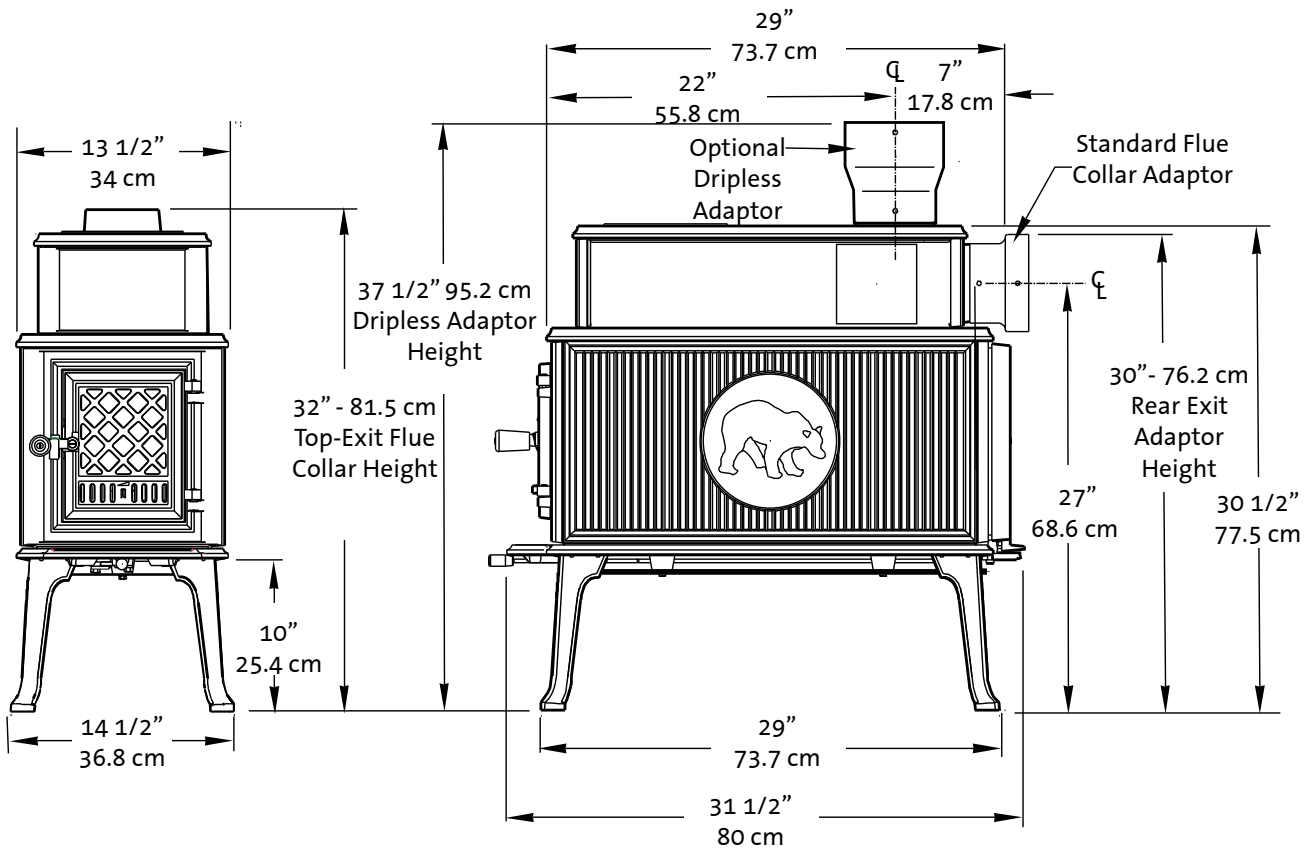

Accessories

Dripless Flue Collar Adaptor #950083

For use in Top Exit installations, this adaptor has a double lip to keep potential combustion by-products within the stove.

Rear Heat Shield #320098

Installation of the rear heat Shield will allow clearance reduction to combustible material. See pages 12 and 13 for details.

Side Heat Shield #320099

Installation enables clearance reductions to combustible materials on that side of the stove.

Spark Screen #350556

Enjoy the warmth of open door fire-viewing with use of this custom fit spark screen.

Stove-Top Thermometer #5002

We recommend the use of a magnetic stove-top thermometer to monitor the surface temperature of the stove.

The optimum surface temperature range for the most efficient performance is between 400° F - 600° F (205° C - 316° C).



Installation and Operation Instructions for USA/Canada

Installation et fonctionnement pour Canada

Safety notice: If this solid fuel room heater is not properly installed, a house fire may result. For your safety, follow the installation directions. Contact local building or fire officials about restrictions and installation inspection requirements in your area. Save these instructions for future reference.

Avis de sécurité: Une installation non appropriée de ce poêle de chauffage risque de provoquer un incendie. Assurez votre sécurité en respectant les directives d'installation suivantes. Consultez les autorités locales du bâtiment ou de la prévention des incendies au sujet des restrictions et exigences relatives aux inspections d'installations dans votre région.

Standards

The Jøtul F118 woodstove has been tested and listed to:

U.S.: ANSI/UL 1482 and ANSI/UL 737

Canada: CAN/ULC-S627-M93

Tests performed by:

ITS, Intertek Testing Services
Middleton, WI



Manufactured by:

Jøtul AS, P.O. Box 1411, Fredrikstad, Norway

Distributed by:

Jøtul North America
55 Hutcherson Drive
Gorham, Maine 04038-2644

The Jøtul F 118 meets the U.S. Environment Protection Agency's Emissions limits for wood heaters manufactured and sold after July 1, 1990.

Under specific laboratory test conditions, this heater has shown heat output at rates ranging from 12,000 to 23,500 BTU's per hour. Actual heat output will vary depending upon fuel type and quality, home design, climate, environment, operation, and chimney function.

The Jøtul F118 woodstove is only listed to burn solid wood only. Do not burn any other fuels.

Read this entire manual before you install and use your new Jøtul F 118 wood stove.

Save these instructions and make them available to anyone using or servicing the stove.



NATIONAL FIREPLACE INSTITUTE
NFI
CERTIFIED
www.nficertified.org

We suggest that our woodburning hearth products be installed and serviced by professionals who are certified in the U.S. by the National Fireplace Institute® (NFI) as NFI Woodburning Specialists or who are certified in Canada by Wood Energy Technical Training (WETT).



Wood Energy
Technical Training
www.wettinc.ca

Check Building Codes

When installing, operating and maintaining your Jøtul F 118 woodstove, follow the guidelines presented in these instructions, and make them available to anyone using or servicing the stove.

Your city, town, county or province may require a building permit to install a solid fuel burning appliance.

In the U.S.: the National Fire Protection Association's Code, NFPA 211, *Standards for Chimneys, Fireplaces, Vents and Solid Fuel Burning Appliances*, or similar regulations, may apply to the installation of a solid fuel burning appliance in your area.

In Canada: the guideline is established by the CSA Standard, CAN/CSA-B365-M93, *Installation Code for Solid-Fuel-Burning Appliances and Equipment*.

Always consult your local building inspector or authority having jurisdiction to determine what regulations apply in your area.

Tools Required:

- Measuring Tape
- 10 mm open-end or socket wrench
- 3 mm hex key
- Work Gloves
- Safety Glasses
- Tin snips
- Phillips Screwdriver

Accepted For Use
City of New York
Department of Buildings
MEA 429-07-E
Jøtul North America, Inc.

Safety Notices

- Burn solid wood fuel only
- Do not use chemicals or fluids to start the fire. Do not burn garbage or flammable fluids.
- If this room heater is not properly installed, a house fire may result. To reduce the risk of fire, follow the installation instructions. Failure to follow these instructions may result in property damage, bodily injury, or loss of life.
- Contact the local building or fire officials about restrictions and installation inspection requirements in your area.
- Do not connect this stove to any air distribution duct or system.
- Extremely hot while in operation! Keep children, clothing and furniture away. Contact will cause skin burns.
- Install smoke detectors in the living areas and bedrooms of your home. Test them regularly and install new batteries twice annually.

When installed in the same room as the stove, a smoke detector should be located as far from the stove as possible to prevent it from sounding when adding fuel to the fire.

- Avoid creating a low pressure condition in the room where the stove is operating. Be aware that operation of an exhaust fan or clothes dryer can create a low pressure area and consequently promote flow reversal through the stove and chimney system. The chimney and building, however, always work together as a system - provision of outside air, directly or indirectly to an atmospherically vented appliance will not guarantee proper chimney performance. Consult your local Jøtul authorized dealer regarding specific installation/performance issues.
- Jøtul recommends that this stove be installed by a professional solid fuel technician or that you consult one if you do the work yourself. Also, consult your insurance company regarding any other specific requirements.

1.0 Installation

If this solid fuel room heater is not properly installed, a house fire may result. For your safety, follow the installation directions. Contact the local building or fire officials about restrictions and installation inspection requirements in your area.

Your local officials have final authority in determining if a proposed installation is acceptable. Any requirement by the local authority having jurisdiction that is not specifically addressed in this manual, defaults to NFPA 211, and local codes in the U.S. or in Canada, CAN/CSA-B365-M and local codes.

1.1 Assembly Before Installation

Unpack the Stove

Inspect the stove for damage. Contact your dealer immediately if any damage is found. Do not install the stove if any damage is evident.

Contents:

- 6" Pipe Adaptor
- Door Handle Knob and hardware
- Air Control Knob
- Pipe Adaptor Screws, M6x16 Hex Hd (2)
- 3 mm hex key

1.2 Flue Collar Installation

The Flue Collar is oriented in the Rear Exit position.

Follow this procedure to change the collar to a Top Exit or Side Exit position if appropriate. You will need a 10 mm open end wrench or socket wrench.

1. Reach through the flue collar opening and remove the two 10 mm bolts that secure it to the rear panel.
2. Remove the two 10 mm bolts that secure the Cover Plate to either the Top or Side Plate as desired.
3. Re-install the Flue Collar on the appropriate position and attach the Cover Plate to the rear panel using the screws previously removed.

1.3 Remove Air Control Limit Bolt

Remove the 10mm Air Control Limit bolt from the bottom of the stove as shown in fig. 1. This bolt is not required in the U.S. and Canada. See also pages 14-15, Section 5.3 for further information.

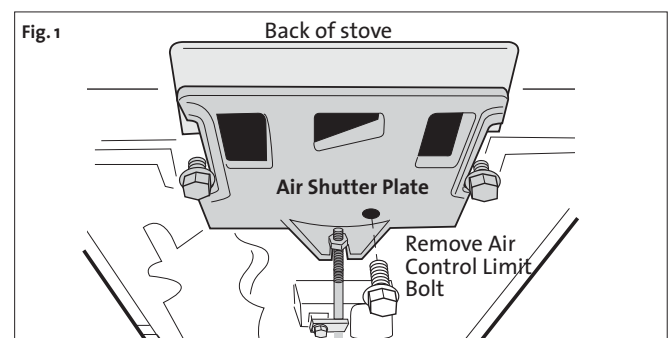

USA/Canada

1.4 Bottom Heat Shield Installation

The bottom heat shield attaches using the two 10 mm bolts that are pre-installed in the stove bottom. **The bottom heat shield must be installed unless the stove hearth is composed of poured concrete on earth.**

1.5 Heat Shield Installation

The shields are perforated to enable you to use tin snips to remove material to accommodate the Flue Collar position your installation requires.

Rear Heat Shield:

1. Remove the set screw located at the center of the stove back plate using the 3 mm hex key included with your stove.
2. Engage the heat shield stand-offs with the slot at each side of the back plate and attach the shield to the center hole using the M6 x 45 hex bolt supplied. See **fig. 2**.

Side Heat Shield:

1. Use a 10 mm wrench to loosen the two mounting bolts located under the lip of the stove bottom. See **fig. 3**.
2. Insert the stand-off clips, (attached to the backside of the shield), under the lip of the stove Shoulder Plate and engage the slots in the lower flange with the mounting screws. Tighten the screws.

1.6 Assemble the Door and Control Knobs

1. Locate the white washer between the handle and the knob and attach to the door latch as shown in **fig. 4**.
2. Locate the knob in the hardware bag and screw it on to the end of the air control rod, under the ash lip, as shown in **fig.5**.

1.7 Chimney Connector

Use 6" single wall or listed 6" double-wall stovepipe to connect the stove to the chimney. Single wall stovepipe must be black iron or stainless steel and have a minimum thickness of 24 gauge. Do not use aluminum or galvanized steel pipe for chimney connection - these materials are not suitable for use with solid fuel.

Follow these guidelines regarding chimney connector construction:

- Do not use chimney connector as a chimney. It is intended only as a connection device.
- Each connector section must be oriented with the male (crimped) end pointing toward the stove. See **fig. 6**.
- Secure all connector joints with three sheet metal screws. The connection to the stove flue collar uses the two M6x 16 mm self-tapping screws provided.

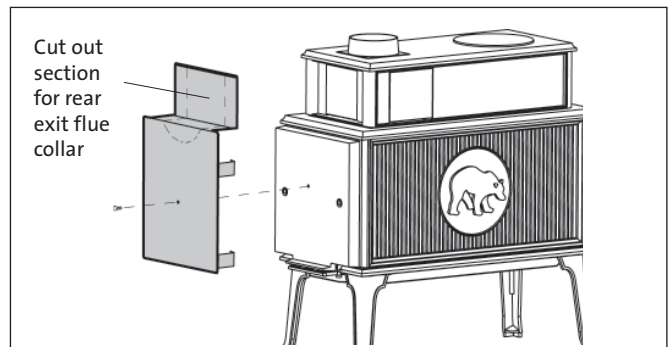

Figure 2.
Install the Rear Heat Shield.

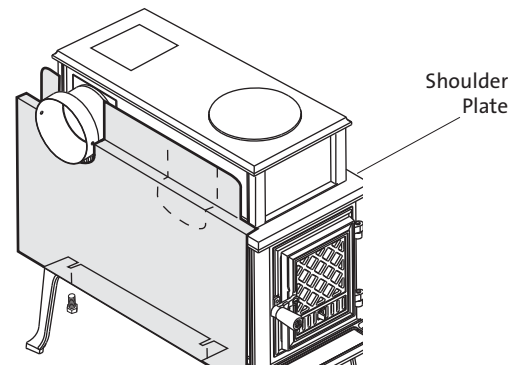

Figure 3.
Install the Side Heat Shield.

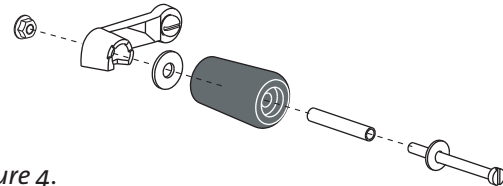

Figure 4.
Load Door latch assembly.

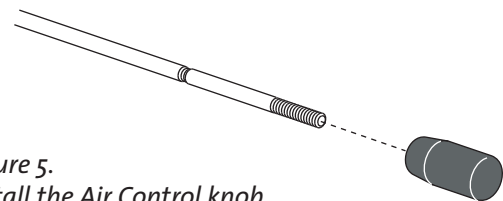

Figure 5.
Install the Air Control knob.

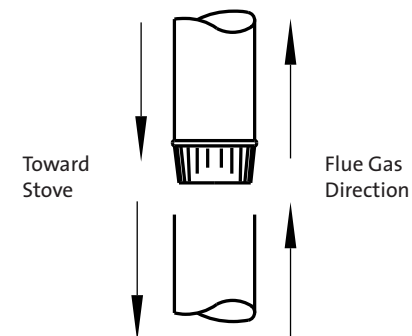

Figure 6.
Chimney connector orientation.

- For the best performance, the chimney connector should be as short and direct as possible, including no more than two 90° elbows.
- **The maximum vertical run of single wall stovepipe should not exceed 10 ft. (305 cm).**
- **The maximum horizontal run should not exceed 3 ft. (92 cm) with a 1/4" rise per foot.** Under no circumstance should horizontal pipe be allowed to slant down toward the chimney.
- No part of the chimney connector may pass through an attic or roof space, closet or other concealed space, or through a floor or ceiling. All sections of the chimney connectors must be accessible for cleaning. Where passage through a wall or partition of combustible construction is desired, the installation must conform with NFPA 211 or CAN/CSA-B365, and is also addressed in this manual.
- **Do not connect this stove to a chimney flue serving another appliance.**

2.0 Chimney Requirements

There are two types of approved chimneys:

1. A code-approved masonry chimney with a ceramic tile or listed steel flue liner.
2. A prefabricated chimney complying with the requirements for Type HT (2100°F) chimneys per UL 103 or ULC S629.

The chimney size should not be less than the cross-sectional area of the flue collar, and not more than three times greater than the cross-sectional area of the flue collar.

When selecting a chimney type and the location for the chimney in the house, keep this in mind: **It is the chimney that makes the stove work - not the stove that makes the chimney work.** This is because a chimney actually creates a suction, called "draft" which pulls air through the stove.

Several factors affect draft: chimney height, cross-sectional area (size), and temperature of the chimney, as well as the proximity of surrounding trees or buildings.

A short exterior masonry chimney will give the poorest performance because it will be difficult to warm the flue and sustain the temperatures necessary to maintain draft strength. In extremely cold climates, it may be necessary to reline the chimney or extend the height to help establish draft.

A tall, interior masonry chimney is easier to keep warm and will perform the best under a variety of weather and environmental conditions.

The following guidelines give the necessary chimney requirements based on the national code (ANSI-NFPA 211 for the US. And CSA CAN-B365 for Canada). However, many local codes differ from the national code to take into account climate, altitude, or other factors. Your local building inspector is the final approving authority. Consult them prior to installation.

Do not connect the stove to any air distribution duct or system.

2.1 Masonry Chimneys

Follow these guidelines when installing the Jøtul F 118 into a masonry fireplace:

- The masonry chimney must have a fireclay liner or equivalent, with a minimum thickness of 5/8" (14 mm) and must be installed with refractory mortar. There must be at least 1/2" (12.7 mm) air space between the flue liner and chimney wall.
- The fireclay flue liner must have a nominal size of 8" X 8" (20 cm x 20 cm), and should not be larger than 8" X 12" (20 cm x 30 cm). A round fireclay liner must have a minimum inside diameter of 6" (15 cm) and maximum inside diameter of 8" (20 cm). A larger chimney should be relined with an appropriate code approved liner.

USA/Canada

- Brick or modular block must be a minimum of 4" (10 cm) nominal thickness. Stone construction must be at least 12" (30 cm) thick.
- A newly-built chimney must conform to local codes, or, in their absence, must comply with national regulations.
- An existing chimney must be inspected by a professional, licensed chimney sweep, fire official, or code officer to ensure that the chimney is in proper working order. Any repairs must be completed before installing the stove.
- No other appliance may be vented into the same flue.
- An airtight clean-out door should be located at the base of the chimney.

2.2 Prefabricated Chimneys

A prefabricated metal chimney must be tested and listed for use with solid fuel burning appliances. High Temperature (HT) Chimney Standard UL 103 for the U.S. and High Temperature Standard ULC S-629 for Canada.

The manufacturer's installation instructions must be followed precisely. Always maintain the proper clearance to combustibles as established by the pipe manufacturer. This clearance is usually a minimum of 2", although it may vary by manufacturer or for certain chimney components.

2.3 Chimney Height

The chimney must be at least 3 feet (92 cm) higher than the highest point where it passes through the roof and at least 2 feet (61 cm) higher than the highest part of the roof or structure that is within 10 feet (3.05 m) of the chimney, measured horizontally.

Chimneys shorter than 14 feet (4.27 m) may not provide adequate draft. Inadequate draft can result in smoke spillage when loading the stove, or when the door is open. Poor draft can also cause back puffing (ignition of gas build-up inside the firebox) and sluggish performance. The minimum height does not, in itself, guarantee proper chimney performance. Optimum draft force should be in the .05 - .10 psi range measured by a Magnahelic gauge.

Excessive chimney height can promote over-strong draft resulting in high stove temperatures and short burn times. Excessive draft can be corrected by installing a butterfly damper. Your Jøtul dealer is an expert resource to consult regarding draft issues or other performance-related questions.

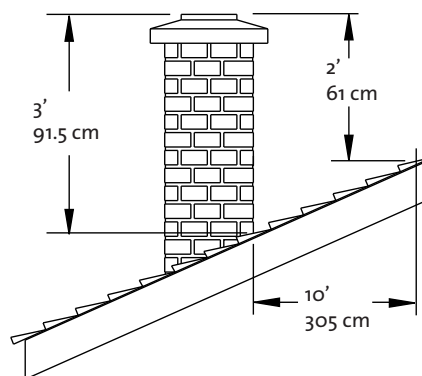

Figure 7. Chimney Height Requirement.

2.4 Wall Pass-Throughs

In the U.S.

The National Fire Protection Association's publication, NFPA 211, *Standard for Chimneys, Fireplaces, Vents and Solid Fuel Burning Appliances* permits four methods for passing through a combustible wall. Before proceeding with any method be sure to consult with your local building officials to discuss any local code requirements.

Common Method:

See fig. 7. Remove all combustible materials from the pass-through area (around the chimney connector), a minimum 12" (30.5 cm). A 6" (15.2 cm) diameter connector will require a 31" x 31" (78.7 x 78.7 cm) square opening.

The opening must be filled with at least 12" (30.5 cm) of brick around a fireclay liner. The liner must be ASTM C35 or equivalent, having a minimum wall thickness of 5/8" (16 mm).

The Pass-through must be at least 18" (45.7 cm) from combustible ceiling materials.

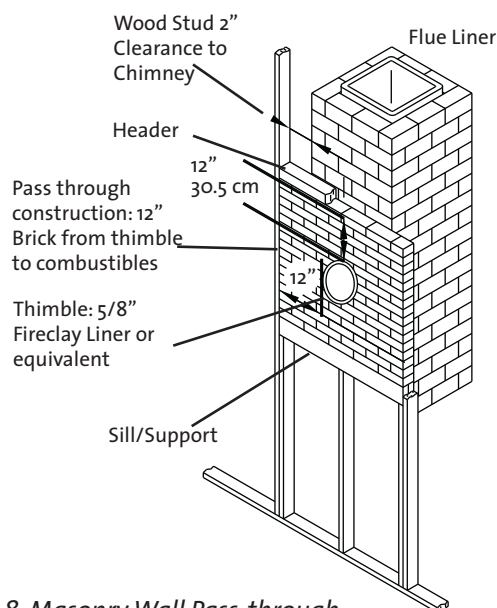

Figure 8. Masonry Wall Pass-through.

It will be necessary to cut wall studs, install headers, and construct a sill frame to maintain the proper dimensions and to support the weight of the brick.

The bricks must be solid brick with a minimum of 3 inches thick (nominal 4"/102 mm).

Refractory mortar must be used at the junction of the chimney and the pass-through liner. The pass-through liner must not penetrate the chimney liner beyond the inner surface of the chimney liner. Use extreme care when constructing the hole in the chimney liner as the tiles can shatter easily.

In Canada

The installation must conform to CAN/CSA-B365, Installation Code for Solid Fuel Burning Appliances and Equipment. Before proceeding be sure to consult your local building inspector.

Common Method:

This method requires the removal of all combustible materials from at least 18" (45.7 cm) around the chimney connector's proposed location. A 6" round liner requires a minimum opening 43" x 43" (109.2 x 109.2) square.

Locate the pass-through at least 18" from combustible ceiling materials.

The space that is cleared of combustible materials must remain empty. Sheet metal panels can be used to cover the area. However, when using a panel on both sides of the wall, each cover must be installed on noncombustible spacers at least 1" from the wall. If one panel of sheet metal is to be used it may be installed flush to the wall.

See section 5.3.1 and 5.3.2 of CAN/CSA - B365-M91. Consult your local building inspector, authorized Jøtul Dealer, NFPA 211 in the U.S. or CAN/CSA-B635 in Canada for other approved wall pass-through methods.

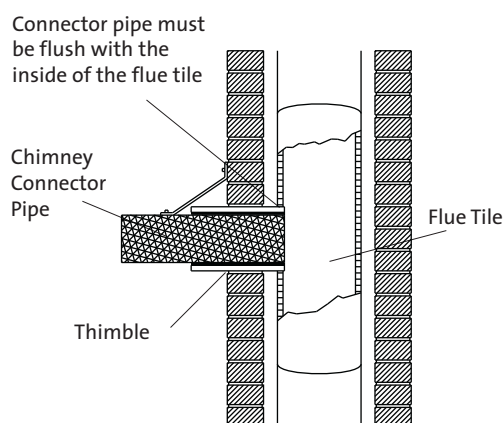

Figure 9. Masonry Chimney Thimble.

3.0 Connecting to the Chimney

3.1 Masonry Chimney

When installing a Jøtul F 118 into a masonry chimney through a "thimble" (the opening through the chimney wall to the flue), the thimble must consist of ceramic tile or steel and be securely cemented in place.

The chimney connector/stove pipe must slide completely inside the thimble to the inner surface or the flue liner. It may be necessary to make use of a thimble sleeve (a pipe with a slightly smaller diameter than standard stove pipe). See **fig. 9**.

The connector pipe or thimble sleeve must not protrude into the flue liner or otherwise restrict draft.

Use refractory cement to seal the seam between the chimney connector, sleeve, and thimble.

Do not connect this stove to a chimney flue servicing another appliance of any kind.

3.2 Hearthmount into a Masonry Fireplace

The Jøtul F 118 may be installed into a masonry fireplace with a minimum opening height of 30 1/2" (77.5 cm).

Building code requires that the fireplace damper plate be removed or securely fixed in the open position.

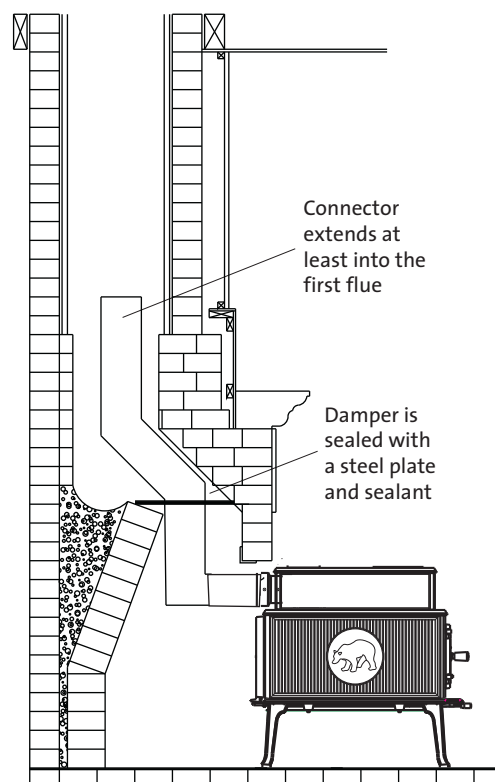

Figure 10. Hearthmount Installation.

USA/Canada

A connector pipe must then extend from the stove's flue exit through the damper area of the fireplace and into the chimney tile liner. See **fig. 10**. In any case, we recommend that a full liner be installed through any masonry chimney to ensure good performance.

The inside area of the flue liner must not be less than the area of the stove flue collar and cannot be more than three times greater than the cross sectional area of the stove flue collar.

If the chimney liner is too large to accommodate the stove, an approved relining system must be installed to resize the flue.

A new sheet metal damper block-off plate must be installed around the connector pipe at the damper frame and sealed with the proper sealant (usually High-Temp Silicone).

3.3 Prefabricated Chimneys

When connecting the Jøtul F 118 to a prefabricated metal chimney always follow the pipe manufacturer's instructions and be sure to use the components that are required. This usually includes a "smoke pipe adapter" that is secured to the bottom section of the metal chimney and allows the chimney pipe to be secured to it with two sheet metal screws. See **fig. 11**.

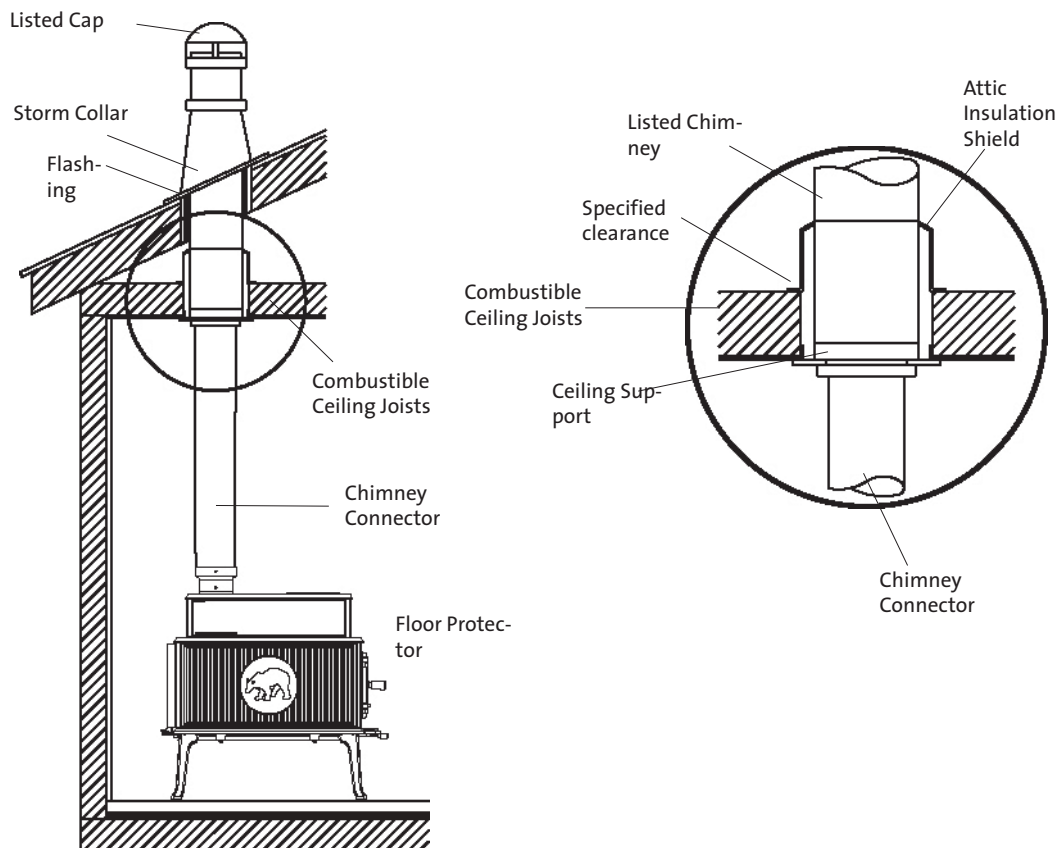

Figure 11. Prefabricated Listed Type HT Chimney.

4.0 Clearance to Combustibles

4.1 Floor Protection

The Jøtul F 118 includes a bottom heat shield. The stove must be installed with the bottom heat shield unless the stove is on a concrete floor poured on earth.

The Jøtul F 118 requires one of the following forms of hearth protection if not installed directly on concrete poured on earth:

- 1) Any UL, ULC, or Warnock Hersey Listed hearth board.
- 2) Any noncombustible material.

All forms of protection must include a noncombustible surface extending forward from the glass panel at least 16" for the U.S., or 18" (46cm) for Canada. Protection must extend 8" (21 cm) from the sides and rear for both the U.S. and Canada.

This will result in a minimum floor protection of 30 1/2" W x 53" D for the U.S. or 30 1/2" W x 55" D for Canada. See **fig. 10**.

In a rear vent installation, the floor protection must also extend under the stove pipe a minimum of 2" (50 mm) beyond either side of the pipe. See **fig. 12**.

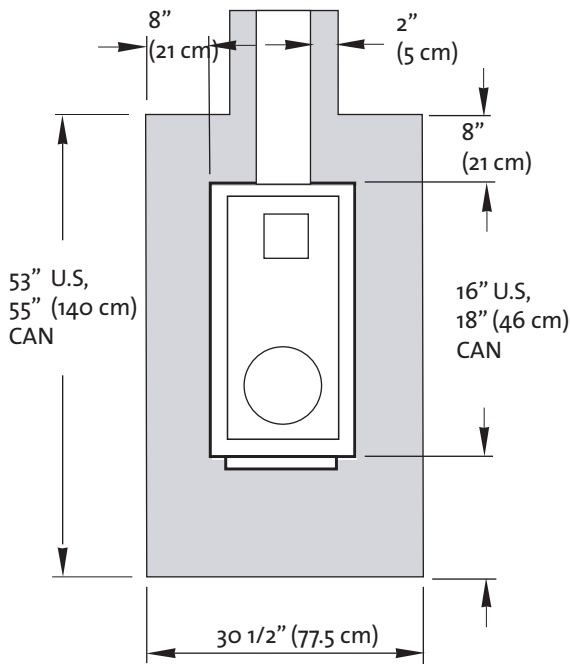

Figure 12. Floor Protection minimum dimensions, U.S. / CAN.

4.2 Clearances to Walls and Ceilings

The clearances listed and diagrammed in this manual have been tested to UL and ULC standards and are the minimum clearances to combustible materials specifically established for the Jøtul F 118.

A combustible surface is anything that can burn (i.e. sheet rock, wall paper, wood, fabrics etc.). These surfaces are not limited to those that are visible and also include materials that are behind noncombustible materials.

If you are not sure of the combustible nature of a material, consult your local fire officials.

Remember: “Fire Resistant” materials are considered combustible; they are difficult to ignite, but will burn. Also “Fire-rated” sheet rock is also considered combustible.

Contact your local building officials about restrictions and installation requirements in your area.

See pages 12-13 for clearance requirements and diagrams.

4.3 Using Shields to Reduce Clearances

Double Wall Connector: Listed double wall pipe is an acceptable alternative to connector pipe heat shields.

Wall-Mounted Protection: When reducing clearances through the use of wall mounted protection:

In the U.S. refer to NFPA 211, Standard for Chimneys, Fireplaces, Vents and Solid Fuel Burning Appliances, for acceptable materials, proper sizing and construction guidelines.

In Canada, refer to CAN/CSA-B365, Installation Code for Solid-Fuel Burning Appliances and Equipment, also for acceptable materials, proper sizing and construction guidelines.

Notice: Many manufacturers have developed woodstove accessories that permit clearance reduction. Use only those accessories that have been tested by an independent laboratory and carry the laboratory’s testing mark. Be sure to follow all of the manufacturer’s instructions.

4.4 Alcove Installation

The Jøtul F 118 can be installed in an Alcove as diagrammed in figure 13.

1. The stove was tested installed with a Rear Heat Shield and single-wall chimney connector.
2. No clearance reduction is obtained with wall shielding installed in an Alcove.
3. Alcove floor protection must consist of a UL/ULC or WHI listed hearth pad or a non combustible material.
4. Minimum ceiling height in an **unprotected** installation, from the floor is 84”(214.3 cm). The stove was not tested with ceiling protection installed.

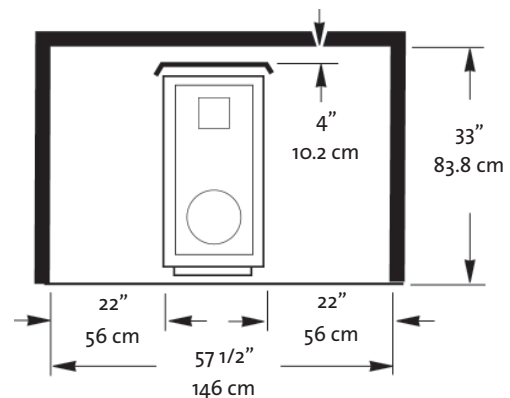

Figure 13. Alcove without Wall Protection.

Jøtul F 118 Clearance Specifications

Measure clearances from the combustible surface to the closest stove surface.

STOVE CLEARANCES	UNPROTECTED SURFACE INSTALLATION			PROTECTED SURFACE INSTALLATION PER NFPA211 OR CAN/CSA -B365-M93		
	SIDE	REAR	CORNER	SIDE	REAR	CORNER
Stove - No Heat Shield, Single Wall Pipe	A 35" / 89 cm	B 9" / 23 cm	C 26" / 66 cm	D 29.5" / 75 cm	E 8.5" / 21.5 cm	F 22" / 56 cm
Stove - Rear & Side H/S with Single Wall Pipe	G 18" / 45.7 cm	H 4" / 10.2 cm	I 12" / 30.5 cm	J 12.5" / 31.7 cm	K* 4.5" / 11.4 cm	L 9.5" / 24 cm
Stove - Rear & Side H/S with Double Wall Pipe	M 18" / 45.7 cm	N 3" / 7.6 cm	O 12" / 30.5 cm	P 12.5" / 31.7 cm	Q 3" / 7.6 cm	R 8.5" / 21.6 cm
Use of Side Heat Shield is not required to obtain rear clearance using Rear Heat Shield only. Use of Rear Heat Shield is not required to obtain side clearance using Side Heat Shield only. Both stove heat shields required for reduced corner clearance.						
Vertical Chimney Connector Clearance	UNPROTECTED SURFACE			PROTECTED SURFACE per NFPA211 or CAN/CSA-B365-M93		
Single Wall Pipe	13" / 33 cm			12.5" / 31.7 cm		
Double Wall Pipe	7" / 18 cm			7" / 18 cm		
Horizontal Connector Clearance	UNPROTECTED SURFACE			PROTECTED SURFACE per NFPA211 OR CAN/CSA-B365-M93		
Single Wall Connector	18" / 45.7 cm			12.5" / 32 cm		
Double Wall Pipe	6" / 15 cm			Use mfg's specification		

K* : As tested, no clearance reduction is obtained with wall shielding

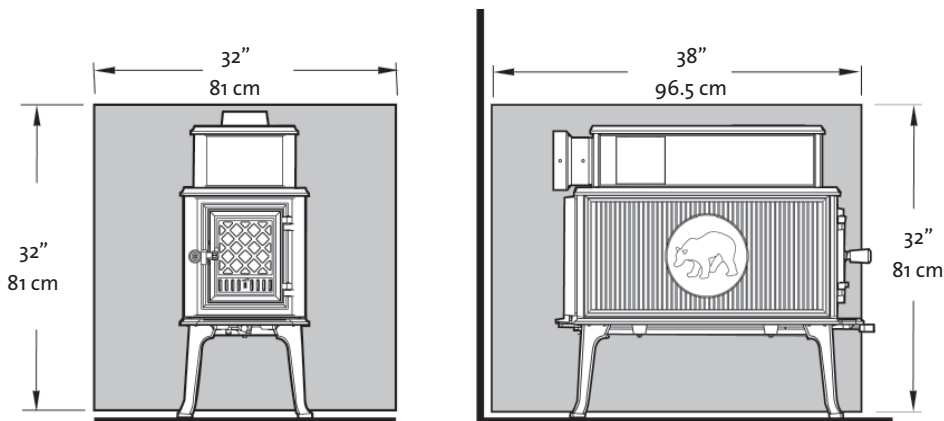
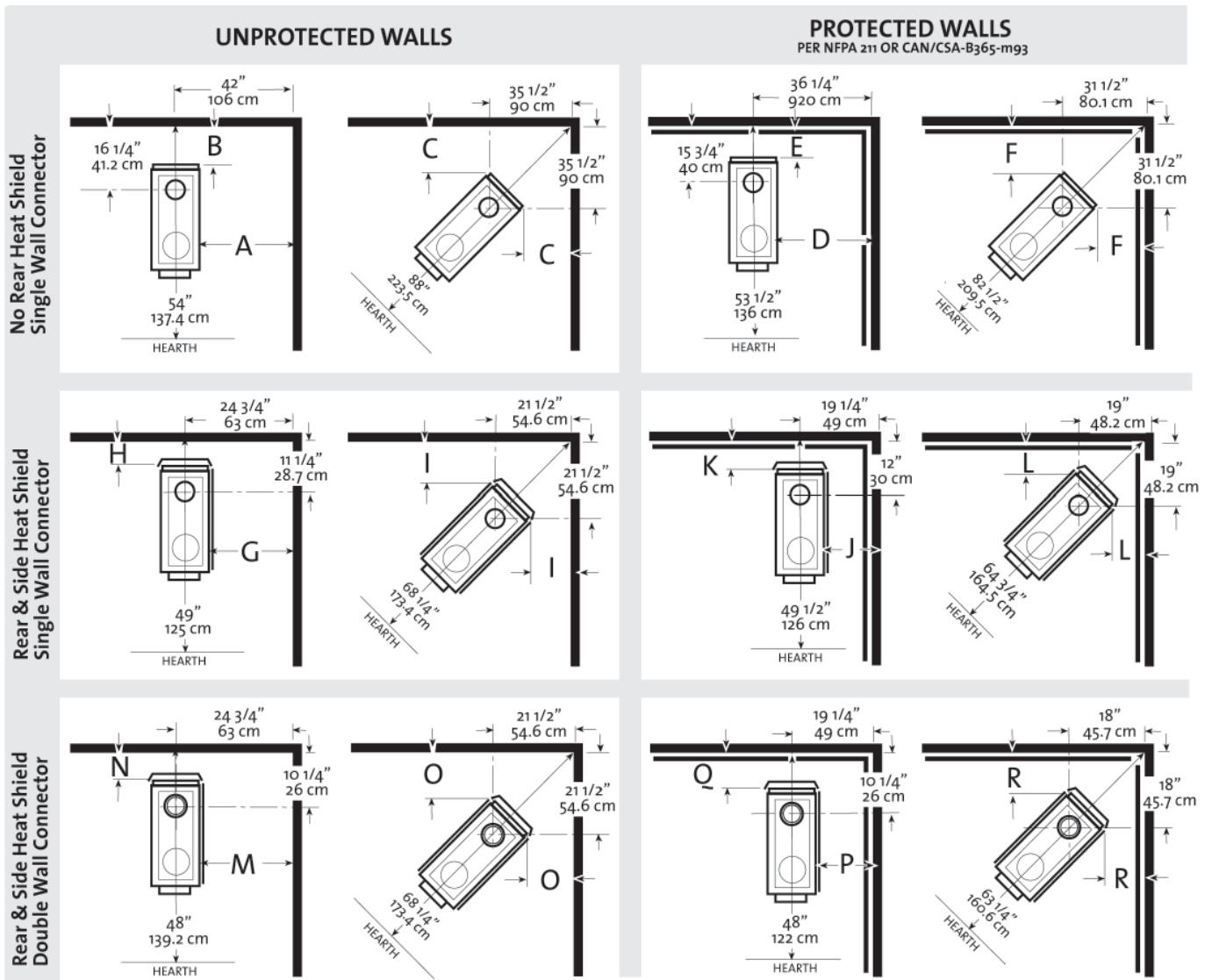

Figure 14. Minimum Wall Shield sizes, centered on stove.
Wall Protection construction must follow NFPA 211 or CAN/CSA guidelines.
Corner wall protection extends 38" from corner.



Canada only: Add 5 cm to all Hearth Extension dimensions shown above.

Clearances to Fireplace Mantels and Surrounding Trim

See the Clearance Chart on page 12 for approved clearances to combustible materials that may be part of fireplace construction.

Mantel Shield Sizing:

Use Rear Wall Shield Sizing, **fig. 14**, or per NFPA 211 guidelines.

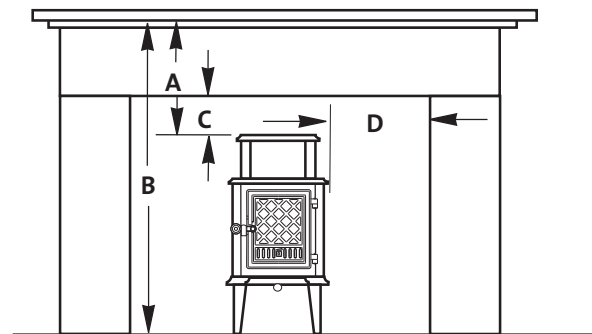

Figure 15. Hearthmount Clearances.

	Unshielded	Shielded
A: Stove to Mantel (12 in. Deep)	13 in. / 33 cm	10 in. / 25.5 cm
B: Floor to Mantel	43 1/2 in. / 110.5 cm	40 1/2 in. / 102.8 cm
C: Stove to 1 in. Deep Top Trim	9 in. / 22.7 cm	5 in. / 12.7 cm
D: Stove to 1 in. Deep Side Trim	15 in. / 38 cm	9 in. / 23 cm

USA/Canada

5.0 Operation

Please read the following section before building the first fire in your new Jøtul F 118.

5.1 Use Solid Wood Fuel Only

This stove is designed to burn **natural wood only**. Wood that has been air-dried for a period of 6 to 14 months will provide the cleanest, most efficient heat.

Do not burn:

- Coal
- Treated or painted wood
- Garbage
- Chemical Chimney cleaners
- Cardboard
- Colored paper
- Solvents
- Any synthetic fuel or logs
- Drift wood
- Laminated wood

The burning of any of these materials can result in the release of toxic fumes. Never use gasoline, gasoline-type lantern fuel, kerosene, charcoal lighter fluid, or similar liquids to start or “freshen-up” the fire. Always keep such liquids away from the heater at all times.

Important: Never build or allow the fire to rest directly on the glass panels. The logs should always be spaced at least one inch from the glass to allow for proper air flow within the firebox.

5.2 How your Jøtul F 118 works

The modern version of the original Jøtul F 118 builds on the strengths of its predecessor; the long, front-to-back burn pattern combines with a baffled heat exchange chamber to promote maximum heat transfer. Your new Jøtul F 118, however, burns fuel substantially more efficiently. The advanced CrossFlow combustion system directs a precise amount of preheated secondary air through stainless steel tubes located along the sides, directly under the baffle at the top of the burn chamber. Volatile gases, released unburned from the fuel bed, rise to the baffle where they are turbulently mixed with the fresh oxygen. Secondary combustion then occurs before the gases pass into the heat exchange chamber. See **fig. 16**.

5.3 Controls on the Jøtul F 118

Combustion is controlled by two air shutters. See **fig. 17**.

Primary Air Shutter (A)

Located in the Load Door, this shutter regulates and directs primary air to the front of the burn chamber. Push it to the right to allow maximum air to support combustion. It should be fully open when first starting or rekindling a fire, or when greater heat output is desired.

FlashFire Lever – Secondary Air (B)

Located directly under the ash lip, the FlashFire Lever is used to regulate secondary air at the rear air inlet. It has three operating positions.

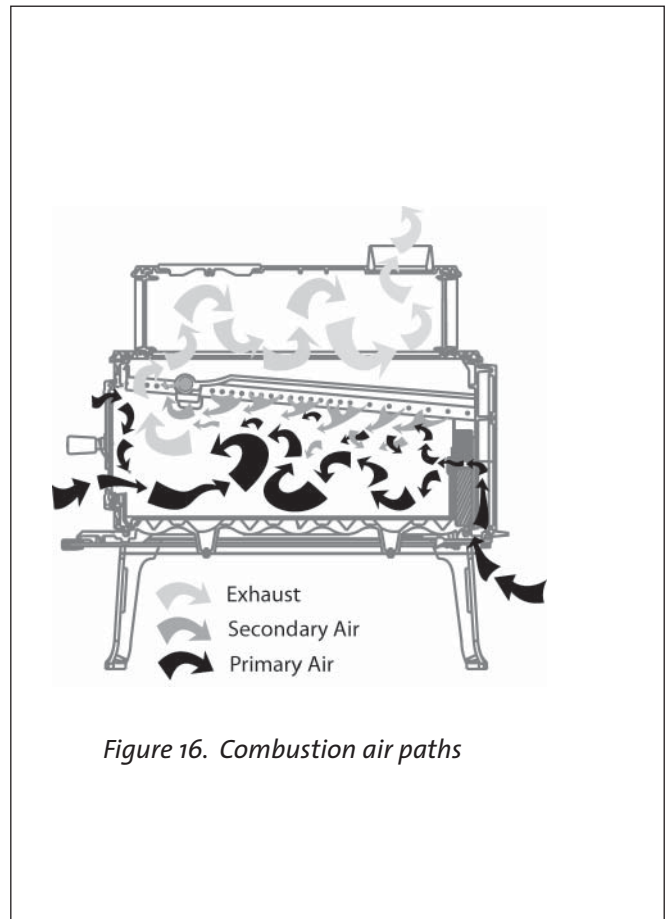

Figure 16. Combustion air paths

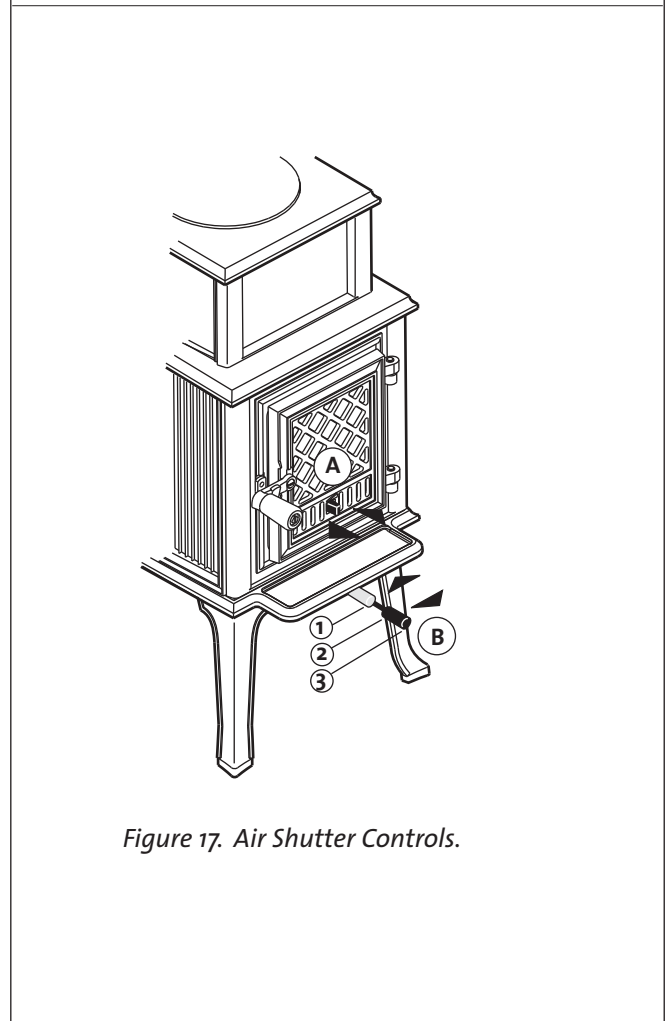

Figure 17. Air Shutter Controls.

Position 1.

This position is not available until the Stop Bolt is removed as shown in fig. 1 on page 5. The lever may then be pushed all the way back to close off all secondary air. This control is intended to help ensure positive draft when first starting a fire in a cold stove or when operating the stove with the load door open and optional spark screen in place.

WARNING. DO NOT USE THIS POSITION TO CONTROL HEAT OUTPUT OR BURN RATE. CONTINUOUS OPERATION AT THIS SETTING WILL STARVE THE FIRE OF SUFFICIENT OXYGEN TO BURN WOOD CLEANLY AND EFFICIENTLY AND WILL CAUSE EXTREME CREOSOTE ACCUMULATION WITHIN THE STOVE AND CHIMNEY.

If you do not intend to use the stove with the optional spark screen, you should consider leaving the Stop Bolt in place to ensure that the stove not be accidentally operated at this setting.

Position 2

Pull the lever forward one stop to open airflow to the rear of the fire and to the secondary air tubes at the top of the burn chamber. This position is used for standard operation to support efficient, complete combustion.

Position 3

Pull the lever fully forward for FlashFire mode. This allows maximum secondary air to the fire to boost heat output. This should not be used for standard, continuous operation.

Clean Glass / Air Wash

A fixed amount of primary air also enters the firebox directly above the glass panel on the door. This incoming air creates a turbulent barrier or «airwash» between the glass and the fire.

5.4 Break-In Procedure

The Jøtul F 118 is constructed of cast iron and high temperature furnace cement. This type of construction requires the stove to be “broken-in” gradually so that heat expansion does not occur too quickly and cause damage. The following steps describe the proper break-in procedure for the Jøtul F118. Use a magnetic stove-top thermometer to monitor stove temperature, placed directly on the top plate.

Set the Primary Air Shutter fully open. Set the FlashFire lever fully closed – all the way back.

1. Light a small fire of newspaper and kindling at the front of the stove. Gradually add small pieces of wood, but only allow the stove to reach a maximum surface temperature of 200°F (93°C). Burn for approximately 1 hour.
2. Allow the stove to cool to room temperature.
3. Light a second fire, allowing the stove to reach a maximum temperature of 300°F (149°C) for 1 hour with the FlashFire Lever in Position 2.

4. Cool the stove to room temperature.
5. Light a third fire and gradually allow the stove to reach a surface temperature of 400°F (204°C)
6. Cool stove to room temperature. This completes the “break-in” procedure.

Note: If the temperature exceeds the limit during any break-in fire, move the Air Shutter all the way to the left to shut off the air supply completely. It is normal that the stovetop temperature will continue to climb until the fuel burns down somewhat. Once the fire is out and the stove has cooled to room temperature, continue the break-in procedure. Never attempt to reduce the temperature by removing burning logs from the fire.

Break-in Odors: It is normal for a newly painted stove to emit odor and smoke during the first few fires. This is caused by curing of the high temperature paint and will diminish with each fire. Open a window or door to provide additional ventilation to alleviate this condition.

5.5 Starting and Maintaining a Fire

Burn only solid wood directly on the bottom grate of the stove. Do not elevate the fire in any way.

1. With the **Primary Air Shutter** in the full open position (to the right), start with several sheets of crumpled newspaper placed directly on the grate at the front of the burn chamber near the load door. On top of the newspaper, place several pieces of small dry kindling* (less than 1” in diameter) with two to three larger logs (approx. 3” to 4” in diameter) on top.
2. The **FlashFire Lever** should be in the fully closed position – pushed all the way back.
3. Light the fire and close the door, slowly building the fire by adding larger and larger logs. Be sure to follow the break-in procedure before creating a hot fire that might damage the stove.
4. Once the stove has reached a surface temperature range of between 400° and 600°, (204°C -316°C), adjust the primary air control lever as necessary to generate the heat output and burn time desired. Set the FlashFire Lever in Position 2 for standard operation over extended periods.

We recommend use of a magnetic stovetop thermometer to monitor the surface temperature of the stove. The optimum surface temperature range for the most efficient burn is between 400° and 600° (204°C -316°C).

You can also monitor stove performance through the window. Peak combustion efficiency occurs when exhaust gas is burned at the baffle in the top of the firebox. This is apparent as yellow flames appearing at the secondary air ports in the underside of the baffle plate.

Never over-fire the stove. If any part of the stove or chimney glows, you are over-firing. A house fire or serious damage to the stove or chimney could result. If this condition occurs, immediately close the air control.

USA/Canada

5.6 Adding Fuel

When reloading the stove while it is still hot and a bed of hot embers still exist, follow this reloading procedure:

- Always wear gloves when tending to the stove.
- Open both the Primary Air Shutter and the FlashFire Lever to the full open position and wait a few seconds before opening the load door. This will allow fresh air to flush the firebox and prevent smoke escaping when the door is opened..
- Use a stove tool or poker to distribute the hot embers equally around the firebox.
- Load the fuel, usually with smaller logs first.
- Close the door, be sure to latch the door tightly.
- Wait 5 – 10 minutes before setting the air controls for the desired heat output and burn time. (If you have at least a 2” thick ember bed when reloading, it may be possible to close the door and immediately adjust the air control setting).
- Set the Air Sutter on the door for the desired heat output.

5.7 Open Door Fire-viewing

Warning: This stove should be operated with the door either fully open with optional Spark Screen in place or with the door fully closed. If the door is left partly open, there is risk of overfiring. Also, gas and flame may be drawn out of the fireplace stove opening, creating risks from both fire and smoke.

Be aware that when operating with the door open, there exists the possibility of generating carbon monoxide by some fuels (e.g. charcoal), and the hazards of carbon monoxide. Be sure adequate fresh air and ventilation is available to the stove.

Creosote Formation and the Need for Removal

When wood is burned slowly, it produces tar and other vapors that combine with moisture to form creosote. Creosote vapors condense in the relatively cool chimney flue, and creosote residue accumulates on the flue lining. When ignited, this creosote fuels an extremely hot fire.

The chimney connector and chimney flue should be inspected at least twice monthly during the heating season to determine if creosote buildup has occurred.

If creosote has accumulated, it should be removed to reduce the chance of a chimney fire.

In the event that creosote ignites in the flue, the resulting fire is often accompanied by a roaring noise and crackling sound as flakes of burning creosote break loose. If you suspect you are having a chimney fire, immediately close the air controls and make sure the door is closed securely. Call the fire department and have everyone leave the house.

Do not attempt to extinguish the fire. Opening the door will only supply additional oxygen and intensify the fire. When the fire in the flue has subsided, resist the temptation to open the door to check on the fire. The fire may have suffocated, but could re-ignite with a supply of fresh air. After a chimney fire, do not use the stove until the chimney connector and flue have been cleaned and inspected to ensure no damage has been sustained.

See Section 6.6 of this manual regarding chimney cleaning.

5.8 Ash Removal

Ash removal will be required periodically, depending on how frequently the stove is used. Avoid letting the ash accumulate to spill over the front lip. For your protection, always wear safety gloves when handling the ashes. Use an ash shovel to remove the accumulation from the bottom of the firebox. It is a good idea to leave a bed of ash in the stove bottom to promote longer burn times and easy start-up.

Ashes should only be placed in a metal container equipped with a tight sealing lid. The container should be placed on a noncombustible floor or on the ground, well away from all combustible materials, pending final disposal. If the ashes are disposed of by burial in soil or otherwise locally dispersed, they should be kept in the closed container until all cinders have thoroughly cooled.

6.0 Maintenance

6.1 Glass Care

Cleaning

On occasion it will be necessary to clean the carbon deposits and fly ash off of the glass. If the carbon and fly ash are allowed to remain on the glass for an extended period of time it could eventually cause the glass to become etched and cloudy. Any creosote that might develop on the glass will burn off during the next hot fire.

Follow this glass cleaning procedure:

1. Glass needs to be completely cool.
2. Only use a cleaner that is specifically designed for this purpose. The use of abrasives will damage the glass and ultimately leave the glass frosted.
3. Rinse and dry glass completely before burning the stove.

Caution! Always operate the door slowly and carefully to avoid cracking or breaking the glass. Never use the door to push wood into the firebox. If the glass becomes cracked or broken follow the replacement procedure below.

Never operate the stove with a cracked or broken glass panel.

Important: Replace glass only with ceramic glass panel PN 128101 specifically designed for the Jøtul F 118. Do not use substitutes. Replacement glass is available from your local Jøtul dealer.

6.2 Glass Removal or Replacement

See **fig. 18**.

1. Place the door face down on a protected surface.
2. Remove the two screws from the Air Wash Manifold and remove the manifold.
3. Remove the two screws from the Lower Air Manifold and remove the manifold with gasket.
4. Lift the glass panel out of the door.
5. Replace the parts in the same order in which they were removed.

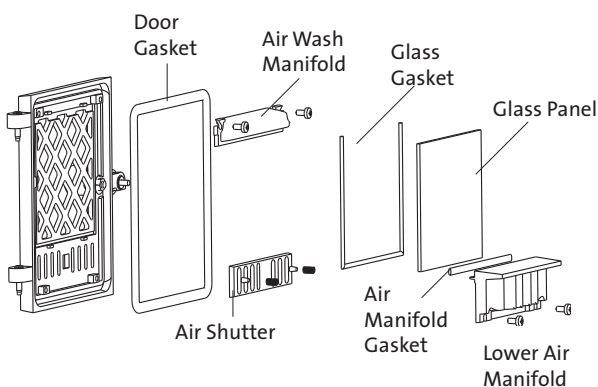

Figure 18. Glass and Gasket Replacement

6.3 General Care

Like your car, regular maintenance prolongs the life of your stove. The following procedures do not take long and are generally inexpensive, but when done consistently, increase the life of your stove and in turn, increase your years of enjoyment.

Enamel Care:

- DO NOT ATTEMPT TO CLEAN HOT ENAMEL SURFACES. Clean only cold enamel surfaces with a soft damp cloth and polish with a clean dry cloth.
- DO NOT USE SOAPY OR ABRASIVE SOLUTIONS. These can cause stains. Coffee, tea, and fruit juices will also cause stains.
- Avoid contact with metal objects. Trivets, kettles, or pots, can damage the enamel.
- Empty stove of all soot and ashes. Only use a vacuum for this job if the vacuum is specifically designed for ashes.
- Inspect the stove: Using a strong light inspect the stove inside and out for cracks or leaks. Replace all cracked parts and repair any cement leaks with furnace cement.

6.4 Gaskets

Check door and glass panel gaskets for tightness. To check the seal of the front door, close and latch the door on a dollar bill and slowly try to pull the dollar bill free. You should feel resistance as you pull. If it can be easily removed, the seal is too loose. Check several spots around the door.

6.5 Gasket Replacement

1. Use pliers and a putty knife to remove the old gasket from the door.
2. Thoroughly clean the channel with a wire brush.
3. Apply a small bead of cement to the channel.
4. Gently press the new gasket into the cement to seat it in the channel. Close and latch the door and then reopen. Wipe away any excess cement that may have squeezed out from around the gasket.

Gasket List for the Jøtul F 118

Description	Size	Length
Top Plate Gasket	3/8" LD	7 ft
Flue Collar Gasket	LD/SA	3 ft
Glass Gasket	LD 187-1	4.8 x 600 m
Door Gasket	LD 360 mm	8.7 x 850 mm
Air Manifold Gasket	LD V-125	8 x 150 mm

6.6 Chimney System

The Jøtul F 118 is designed to burn cleanly and efficiently when used according to the guidelines in this manual. In order to maintain proper performance, you should inspect the chimney and chimney connector at the beginning of each heating season and then, twice a month during the heating season. Clean the chimney whenever creosote and fly ash accumulation exceeds 1/4 inch in any part of the system.

Chimney brushes are available from your local Jøtul dealer or hardware supply store. Your dealer can also refer you to a reputable, professional chimney sweep who will have all the equipment to ensure a complete and proper job. Failure to keep the chimney system free of creosote and build up could result in a serious chimney fire.

Only use replacement parts provided through your authorized Jøtul dealer.

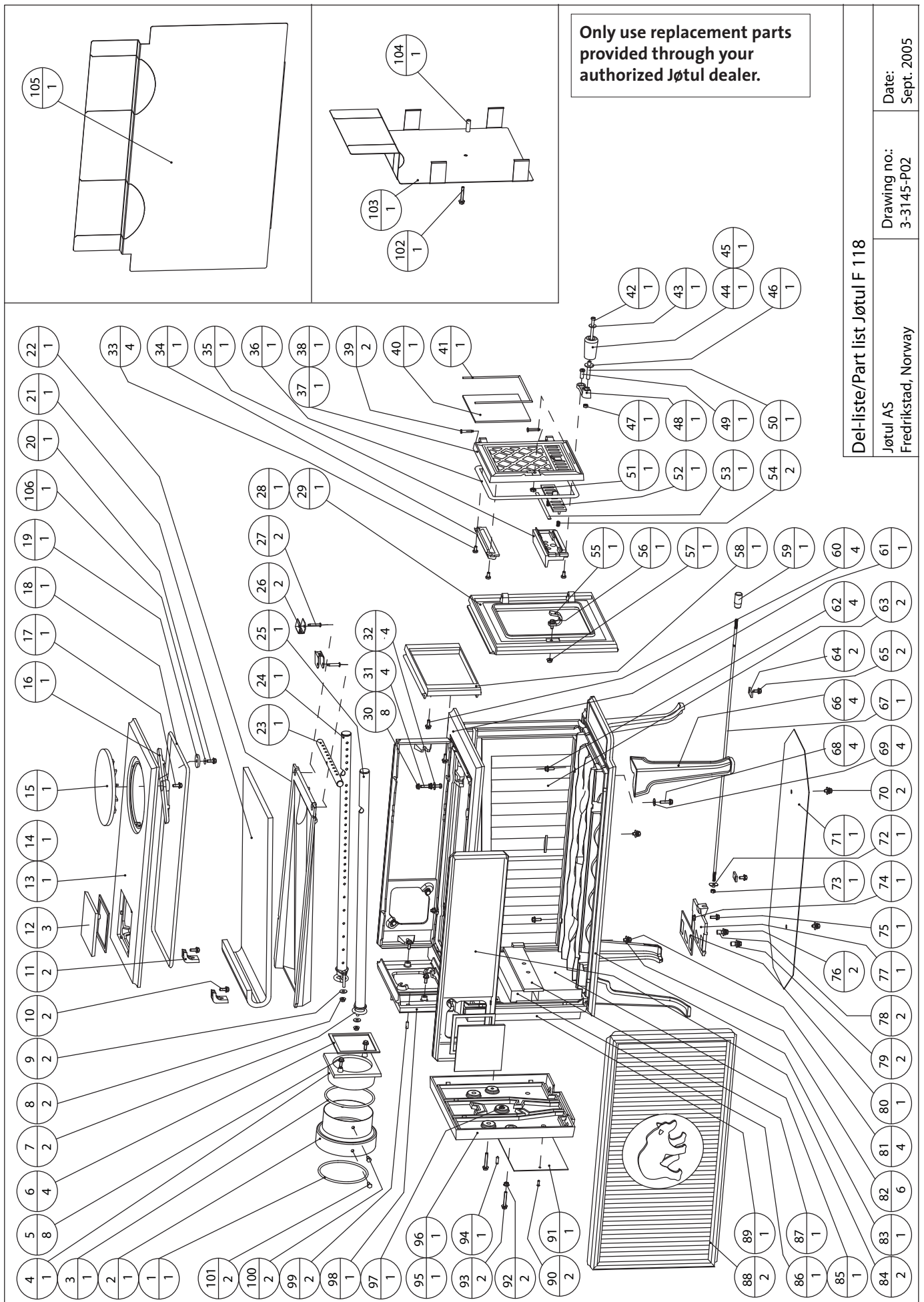

Del-liste/Part list Jøtul F 118
 Jøtul AS
 Fredrikstad, Norway
 Drawing no.: 3-3145-P02
 Date: Sept. 2005

Figure 19. Illustrated Parts Breakdown

USA/Canada

Part numbers

Pos. no. Description

1	Gasket for smoke outlet	59	Knob Secondary Air
2	Adaptor	60	Screw, Hexagon Cap Flange
3	Gasket for smoke outlet	61	Top Plate, lower
4	Smoke Outlet	62	Screw, Hexagon Cap Flange
5	Screw, Hexagon Cap Flange	63	Burnplate L/R
6	Gasket for smoke outlet	64	Clip
7	Gasket for secondary air tubes	65	Screw, Hexagon Cap Flange
8	Nut Hexagon Cap Flange	66	Leg
9	Washer	67	Regulating Bar Secondary Air
10	Screw, Hexagon Cap Flange	68	Screw, Hexagon Cap Flange
11	Bracket for top/sidepiece	69	Washer
12	Smoke outl cover	70	Screw, Hexagon Cap Flange
13	Top, upper, complete	71	Heatshield, bottom
14	Top Plate Upper	72	Weld Nut
15	Cooking Plate	73	Nut Hexagon Cap Flange
16	Traverse	74	Nut Hexagon Cap Flange
17	Screw, Hexagon Cap Flange	75	Screw, Hexagon Cap Flange
18	Gasket	76	Screw, Hexagon Cap Flange
19	Washer, cast Iron	77	Sliding valve rear
20	Screw, Hexagon Cap Flange	78	Sleeve
21	Insulating Blanket	79	Screw, Hexagon Cap Flange
22	Baffle	80	Gasket, secondary air
23	Air tube, secondary, front	81	Screw, Hexagon Cap Flange
24	Air tube, secondary, right	82	Washer
25	Air tube, secondary, left	83	Bottom Plate compl
26	Baffle Clip	84	Side plate, upper
27	Hinge pin	85	Brick Refractory
28	Front, lower	86	Brick Refractory
29	Front, lower, complete	87	Brick retainer
30	Nut Hexagon Cap Flange	88	Side plate, lower
31	Screw Hex	89	Rear Plate, lower inner
32	Washer	90	Rivet stee/steel
33	Screw MachPanh Poz	91	Label Plate
34	Air deflector	92	Nut Hexagon Cap Flange
35	Valve Holder For Door	93	Screw, Hexagon Cap Flange
36	Gasket for Door	94	Screw SocketSet w/Cone
37	Door	95	Rear plate outer, complete
38	Door incl Glass	96	Rear plate outer
39	Hinge pin	97	Blind Rivet Nut M6
40	Glass	98	Rear Plate, upper
41	Gasket for glass	99	Screw SocketSet w/Cone
42	Screw Cylh slotted	100	Screw Hex Selfth
43	Washer	101	Screw Hex Selfth
44	Door Knob wood	102	Screw, Hexagon Cap Flange
45	Plastic bag w/parts	103	Heatshield rear
46	Washer insulating	104	Sleeve
47	Nut Hexagon Cap Flange	105	Heatshield side
48	Latch	106	Washer Ø6.4xØ18x1.6 Untreated Surface
49	Screw Cylh slotted		
50	Sleeve		
51	Nut Hexagon Cap Flange, low		
52	Sliding valve (Door)		
53	Gasket for Sliding valve (door)		
54	Spring For Door With Glass		
55	Door Catch		
56	Screw, Hexagon Cap Flange		
57	Nut Hexagon Cap		
58	Front Plate, upper		

Draw.no 4-4502-Po2

7.0 Jøtul N. A. wood-burning product limited warranty

Effective February 1, 2010

This warranty policy applies to wood-burning products identified by Jøtul and Scan trade names, as set forth below.

A. Cast Iron, Enamel, and Steel Components:

Jøtul North America Inc. (JØTUL) warrants, to the original retail purchaser, that those components of the Jøtul or Scan Stove or Fireplace specified above will be free of defects in material and workmanship for a period of five (5) years from the date of purchase. This warranty is subject to the terms, exclusions and limitations set forth in the following text.

B. Electrical Components (blowers, thermostatic switches):

JØTUL warrants, to the original retail purchaser, that those components of the Jøtul or Scan Stove or Fireplace specified above will be free of defects in material and workmanship for a period of one (1) year from the date of purchase. This warranty is subject to the terms, exclusions, and limitations set forth in the following text

JØTUL will repair or replace (including parts & labor), at its option, any of the above components determined by JØTUL to be covered by this warranty. You must, at your own expense, arrange to deliver or ship the component to an authorized Jøtul or Scan dealer and arrange for pickup or delivery of the component after repairs have been made. If, upon inspection, JØTUL determines that the component is covered by this warranty, the repair or replacement will be made as set forth above. This warranty is not transferable and is extended only to, and is solely for the benefit of, the original retail purchaser of the Jøtul or Scan Stove or Fireplace. This paragraph sets forth the sole remedy available under this warranty in the event of any defect in the Jøtul or Scan Stove or Fireplace.

The warranty period for any replaced component will be the remaining unexpired portion of the warranty period for the original component.

Please retain your dated sales receipt in your records as proof of purchase.

Exclusions and limitations

Notice: This warranty is void if installation or service is performed by someone other than an authorized installer or service agency, or if installation is not in conformance with the installation and operating instructions contained in this owner's manual or local and/or national fire and building regulations. A listing of local authorized installers, service agencies and gas suppliers can be obtained from the National Fireplace Institute at <http://www.nficertified.org/>.

This warranty does not cover the following:

1. Repair or replacement of parts that are subject to normal wear and tear during the warranty period or to parts that may require replacement in connection with normal maintenance. These parts include paint, gaskets, burn plates, baffles, air manifolds, firebricks, fire grates, or glass (glass is only warranted against thermal breakage).
2. Damage due to incorrect installations not in conformance with the installation instructions contained in this owner's manual or local and/or national fire and building regulations.
3. Damage, including damage to enamel surfaces, caused by improper operation, over-firing, and/or misuse. Improper operation, such as burning the stove with the ash door open, can damage the stove. Over-firing occurs when any part of the stove glows red. Over-firing can also be identified by warped plates, rust-colored cast iron, paint pigment that has turned dusty white, or bubbling, cracking and discoloration of the enamel finish. Misuse includes, without limitation, use that is not in conformance with the operating instructions contained in this owner's manual.
4. Damage due to service performed by an installer or service agency, unless otherwise agreed to in writing by JØTUL.
5. Damage caused by unauthorized modification, use or repair.
6. Costs incurred by travel time and/or loss of service.
7. Labor or other costs associated with the repair of components beyond the warranty period.
8. Damage incurred while the Jøtul or Scan Stove or Fireplace is in transit.

IN NO EVENT SHALL JØTUL, ITS PARENT COMPANY, SHAREHOLDERS, AFFILIATES, OFFICERS, EMPLOYEES, AGENTS OR REPRESENTATIVES BE LIABLE OR RESPONSIBLE TO YOU FOR ANY SPECIAL, INDIRECT, INCIDENTAL, CONSEQUENTIAL, PUNITIVE OR OTHER SIMILAR DAMAGES, INCLUDING, BUT NOT LIMITED TO, LOST PROFITS, LOST SALES, INJURY TO PERSON OR PROPERTY, OR DAMAGES TO A STRUCTURE OR ITS CONTENTS, ARISING UNDER ANY THEORY OF LAW WHATSOEVER. ALL IMPLIED WARRANTIES, INCLUDING THE IMPLIED WARRANTIES OF MERCHANTABILITY AND FITNESS FOR A PARTICULAR PURPOSE, OR OTHERWISE, ARE LIMITED IN DURATION TO THE LENGTH OF THIS WRITTEN WARRANTY. EXCEPT AS EXPRESSLY SET FORTH HEREIN, JØTUL MAKES NO ORAL, WRITTEN OR OTHER WARRANTY WITH RESPECT TO JØTUL OR SCAN STOVES OR FIREPLACES.

Some states do not allow the exclusion or limitation of incidental or consequential damages, or limitations on the length of implied warranties. Therefore, the above exclusions or limitations may not apply to you. This warranty gives you specific legal rights, and you may have other rights, which vary from state to state.

JØTUL reserves the right to discontinue, modify or change the materials used to produce the Jøtul or Scan Stove or Fireplace. JØTUL shall have the right to replace any defective component with substitute components determined by JØTUL to be of substantially equal quality and price.

USA/Canada

The dollar value of JØTUL's liability for breach of this warranty shall be limited exclusively to the cost of furnishing a replacement component. JØTUL shall not in any event be liable for the cost of labor expended by others in connection with any defective component. Any costs or expenses beyond those expressly assumed by JØTUL under the terms of this warranty shall be the sole responsibility of the owner(s) of the Jøtul or Scan Stove or Fireplace.

No dealer, distributor, or other person is authorized to modify, augment, or extend this limited warranty on behalf of JØTUL. **NO MODIFICATION OR CHANGE TO THIS WARRANTY WILL BE EFFECTIVE UNLESS IT IS MADE IN A WRITTEN DOCUMENT MANUALLY SIGNED BY AN AUTHORIZED OFFICER OF JØTUL.**

An authorized installer may have been provided with certain information related particularly to the Jøtul or Scan Stove or Fireplace; however, no authorized installer or other person who may service the appliance is an agent of JØTUL. No inference should be made that JØTUL has tested, certified, or otherwise pronounced any person as qualified to install or service the appliance. JØTUL shall not be liable or otherwise responsible for any error or omission by a person installing or servicing a Jøtul or Scan Stove or Fireplace.

If you believe your Jøtul or Scan Stove or Fireplace is defective, you should contact your nearest authorized Jøtul or Scan dealer, who will process a warranty claim. **IN ORDER TO QUALIFY FOR WARRANTY COVERAGE, JØTUL MUST RECEIVE NOTICE OF A POSSIBLE DEFECT WITHIN SIXTY (60) DAYS OF THE DATE THE DEFECT IS FIRST DISCOVERED, OR REASONABLY COULD HAVE BEEN DISCOVERED.**

*This warranty is given by Jøtul North America, Inc.,
55 Hutcherson Drive, Gorham, Maine 04038 USA*

Sluttkontroll av ildsteder

Quality control of stoves and fireplaces

Checked

Utført	Kontrollpunkt	Controlled item
✓	Alle deler er med i produktet (ifølge struktur).	All parts are included.
✓	Alle festemidler er av korrekt type, og er korrekt anvendt.	Correct fastener items have been used and correctly applied.
✓	Overflater er i samsvar med Jøtuls kvalitetsstandarder.	Surfaces comply with Jøtul workmanship standards.
✓	Lukkemekanismer fungerer som de skal, og uten behov for unødig stor kraft.	Door locking mechanisms function correctly; excessive force is not needed.
✓	Produktet/serien møter kravet for lekkasjetest.	The product/lot complies with the leakage test requirement.
✓	Lakkerte/emaljerte overflater møter kravene i Jøtuls kvalitetsstandarder.	Paint/enamel surface finish complies with Jøtul workmanship standards.
✓	Produktet er fritt for utvendig kitt- eller limklin.	Surfaces are not contaminated by external stove cement or glue.
✓	Produktet har ingen sprekker i glass, støpejern eller andre deler.	There are no cracks in glass, cast iron or other parts.
✓	Pakninger er riktig lagt, og skjemmer ikke produktet ved stygge ender eller ved at pakningen er unødig synlig.	Gaskets are correctly applied and do not degrade product appearance (i.e. loose ends or excessive visible exposure).
✓	Dørpakninger er godt limt.	Door gaskets are firmly glued/fixed to the door.
✓	Dørpakninger har tilfredsstillende pakningstrykk.	Door gaskets provide satisfactory sealing.
✓	Sjekk at det ikke "lyser gjennom" i dørpakning eller andre sammenføyninger.	Check for "light through" at door seals and other relevant locations.
✓	Trekkhender osv fungerer normalt.	The function of air valve handle etc is normal.

Jøtul bekrefter herved at dette produktet er kontrollert og funnet å være i samsvar med våre kvalitetsnormer.

Jøtul hereby confirm that this product has been QC inspected and found to comply with our quality standards.

Lot. No. / Serie nr. - Checked by / kontrollert av

Cat. no. 10025903 (221549)
Draw. no. 4-4472-POS
Jøtul AS, May 2010

Jøtul pursue a policy of constant product development. Products supplied may therefore differ in specification, colour and type of accessories from those illustrated and described in the brochure.

Quality

Jøtul AS utilizes quality controls conforming to NS-EN ISO 9001 for product development, manufacturing, and distribution of stoves and fireplaces. This policy is intended to provide you with the peace of mind that the Jøtul product you purchase meets or exceeds current uniform standards for quality and safety - a continuation of the standards instituted at the company's inception in 1853.

We appreciate your trust in welcoming our product into your home and invite your comment and appraisal of our efforts to provide you with the finest in home hearth products.

Jøtul AS
P.O. Box 1411
N-1602 Fredrikstad,
Norway

Jøtul North America Inc.
P.O. Box 1157
55 Hutcherson Drive
Gorham, Maine 04038
USA

