

# Blaze King<sup>®</sup>

## OWNER'S INSTALLATION AND OPERATION INSTRUCTION BOOK

**BLAZE KING, Top Vent  
KT-302 and KTJ-302**

**Blaze Princess, Top Vent  
PT-202 and PTJ-202**

**OM-2**

8/21/81  
RCR

# BLAZE KING AND BLAZE PRINCESS

## INSTALLATION AND OPERATION INSTRUCTIONS

You are now the proud owner of a Blaze King® woodstove—the finest, most beautiful woodstove ever introduced in America.

It is the desire of Woodcutters Mfg., Inc. that your stove give you a lifetime of trouble-free operation. We suggest that before starting installation you read these installation and operation instructions.

### WARRANTY

To register your warranty, fill out and return the "Warranty Card" packed with these instructions in the firebox of the stove.

### TEST AND CERTIFICATION

KT-302 and KTJ-302: ICBO Report #3634

PT-202 and PTJ-202: ICBO Report #3634

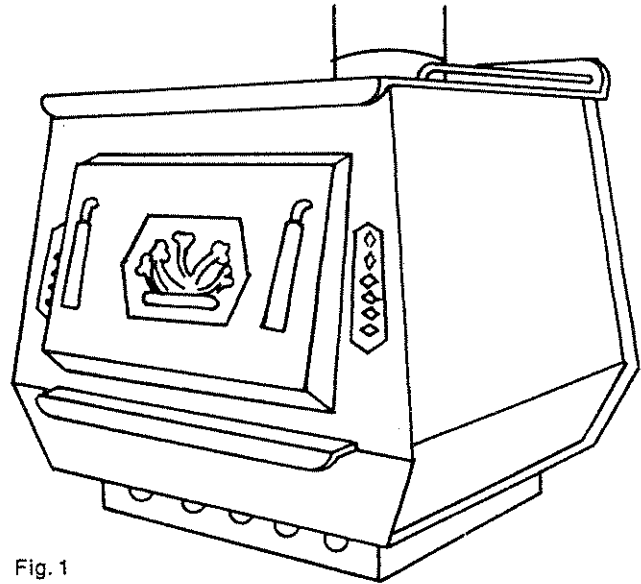

Fig. 1

### DIMENSIONS

Model	Width	Depth	Height	Weight (pounds)
Blaze King				
KT-302	30"	31"	33"	345
KTJ-302	30"	34"	33"	360
Blaze Princess				
PT-202	26"	30"	29"	245
PTJ-202	26"	33"	29"	260

### PRODUCT INSPECTION

First, remove all packaged parts from your stove and inspect them. Make sure that the stove is complete. Examine the pieces to see that there is no damage caused by shipping. Should any part be missing or damaged, contact your dealer.

## CHECK LIST

1. Stove with firebrick installed.
2. Door with gasket material installed.
3. Wood handles.
4. Blower motor and screws (Jet-Air models).
5. Fireplace screen with handle and hardware.
6. Thermostat knob.
7. Smoke shelf.

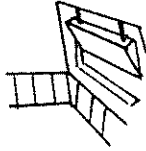

Fig. 2

8. Ceramics—center and sides. (Side ceramics for Jet-Air models must have air holes.)

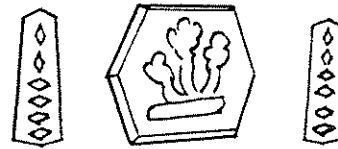

Fig. 3

## IMPORTANT

Improper installation of your Blaze King® woodstove, or failure to operate it according to the guidelines detailed in these instructions, may negate your warranty and endanger your home and family.

For years of carefree, efficient heating, follow building and fire codes during installation and consult these instructions when operating your Blaze King® woodstove.

## SOME CAUTIONS

1. Stoves must be vented **ONLY** to the outside, not to other rooms or buildings.
2. **NEVER** use a chimney connector or chimney flue smaller than the 8" stove exhaust.
3. **NEVER** vent your woodburning stove into a 'Class B' gas vent chimney. Check with local authorities to make sure that you are not doing so inadvertently if you are using an existing chimney.

## BUILDING CODES AND PERMITS

Some areas may require a permit from the city, county, Building Inspector, or Fire Marshal. Check local building codes before beginning installation. After the installation is completed, it should be checked by your local Fire Marshal or Building Inspector before use.

## SELECTION OF STOVE LOCATION

The International Conference of Building Officials (ICBO) will recognize this appliance only if it is connected to an 8", listed, low heat, prefabricated, metal chimney system and minimum clearances to combustibles are observed. See CHIMNEYS and CHIMNEY CONNECTOR.

When deciding exactly where to position your stove, consider that you will want to place the stove as near as practicable to the center of the lowest level of your home for maximum heat efficiency. Hot air rises, so a layer of warm air will form along the ceiling of the lowest level, and spread outward and upward to other areas of the house. Even if your home is entirely on one level, consider placing your stove in an area that will allow natural circulation of air throughout your home to spread the warmth most effectively.

Moreover, the actual placement of your stove must take into careful consideration, factors in the areas through which the pipe venting will occur, including the presence of the electrical wiring, plumbing, ceiling joists, rafters, and the position of suitably strong floor joists, as well as the pattern of foot traffic through the room.

**WARNING:** DO NOT cut ceiling or roof joists.  
DO check floor joists for proper support of the stove.

It is important to remember that in order for your Blaze King woodstove to make the most efficient use of both its radiant heating and/or convective heating capabilities, furniture must be kept well away from your stove. Radiant heat from the stove will strike nearby objects and go no further, creating a "hot spot" in your room, wherein the objects themselves and not the room are warmed. Moreover, the close proximity of furniture and other such combustible objects to your stove may constitute a fire hazard.

## RADIANT AND CONVECTIVE HEAT

All woodburning units use radiant heat—the heat that radiates from a warm object in all directions (like light, from a bulb) and strikes objects in its path, warming them. Like light, when radiant heat is stopped by an object, it will go no further. A "shadow" of cold then develops behind objects that have stopped the radiant heat. With the patented Jet-Air design, Blaze King® woodstoves have added convective heat to the radiant heat already present.

Air moves upward when it is warmed and downward when cooled. This air movement helps to spread warmth through the home. In the Jet-Air models of Blaze King® woodstoves, cool air is drawn from near floor level, warmed as it passes through the heat exchanger manifolds inside the firebox, and passes through the side ceramic decoration into the room. This convection heating distributes the heat to all areas more efficiently.

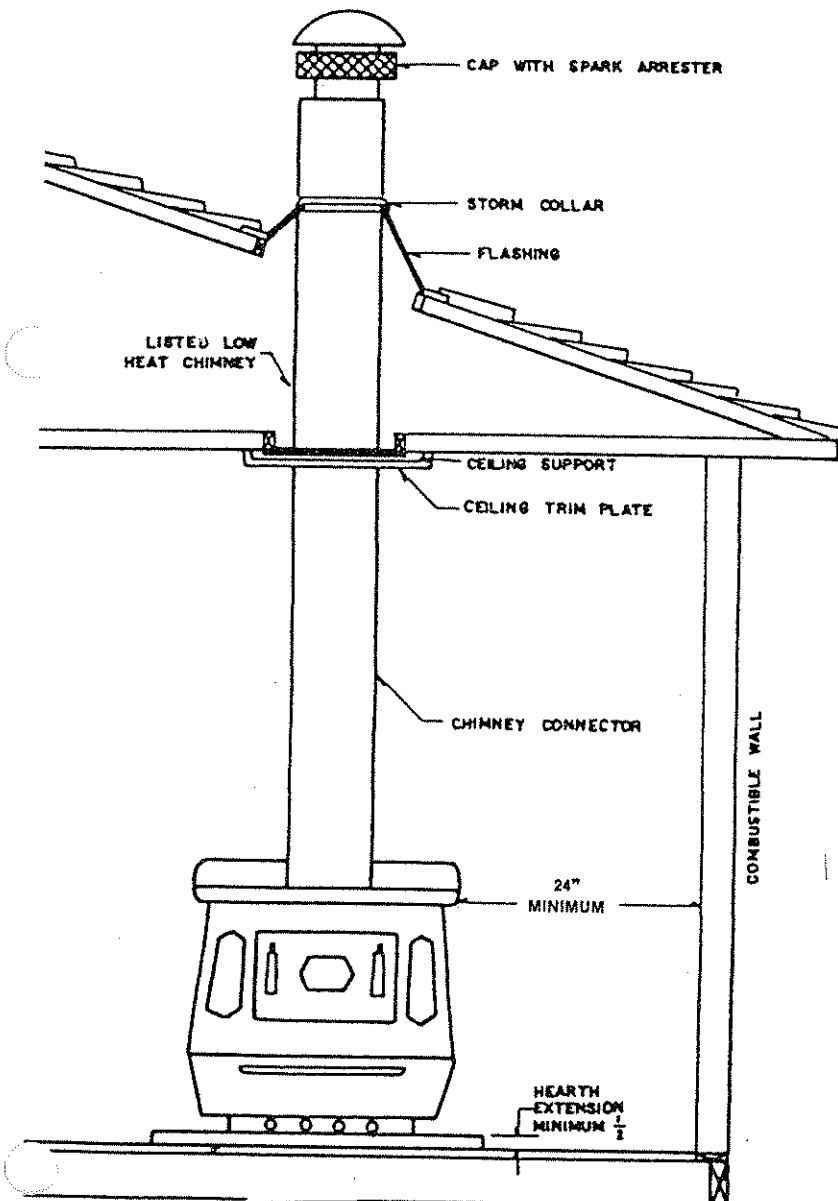

Fig. 4

## PLACEMENT

The stove should be installed no closer than 24" from the side of the stove top and 17" from the back of the stove to unprotected combustible walls. The chimney connector must be no closer than 18" to combustibles.

## FLOOR AND WALL PROTECTION

Consideration must be made for following your local building codes regarding necessary air spaces between non-combustible and combustible materials when installing your stove. **THESE AIR SPACES CANNOT BE IGNORED.** Since sufficient air space constitutes one of the best forms of insulation in the installation of woodburning units, the safety of your home and family will depend largely on how well the local ordinances regarding such air spaces are followed.

The floor area below the stove must be protected with a hearth extension of non-combustible material, 1/2" minimum thickness, extending at least 8" beyond each side of, 21" in front of, and 12" from the back of, the pedestal base of the stove.

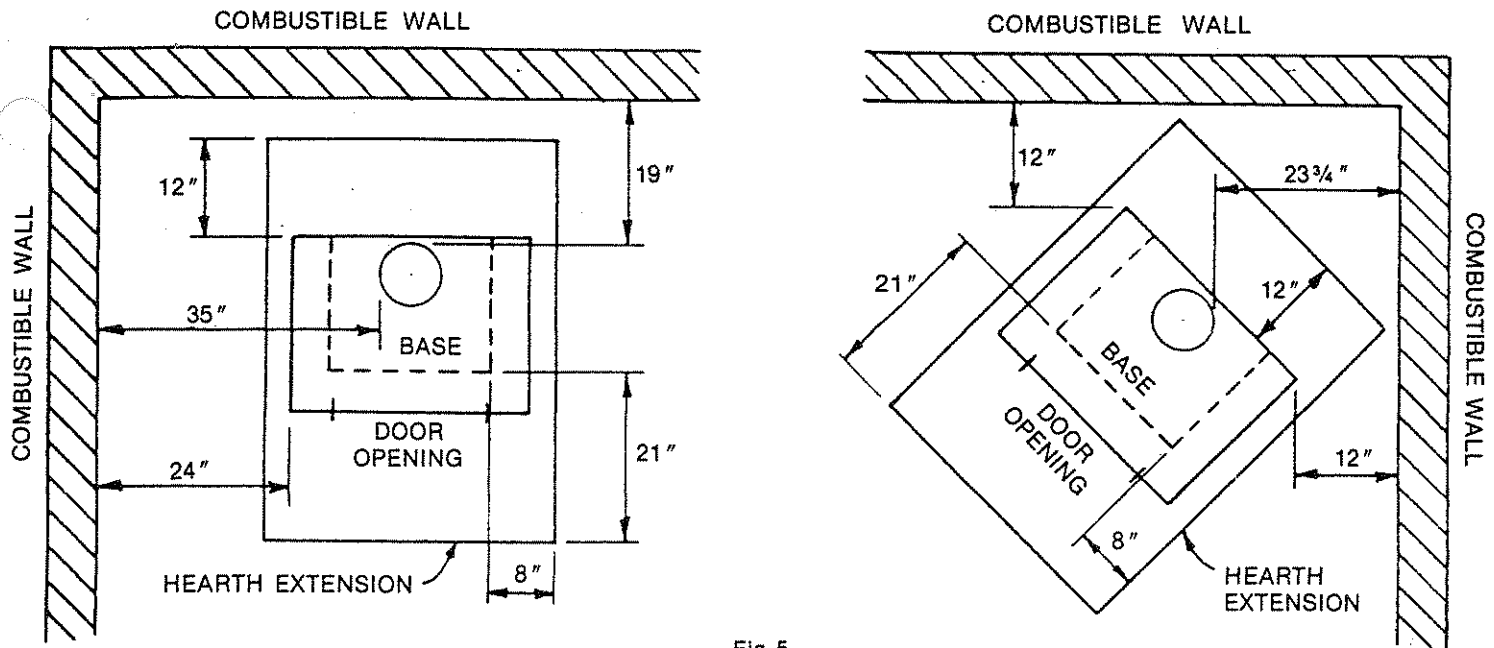

Fig. 5

## CHIMNEYS

Freestanding woodstoves can only be vented into existing chimneys or into an 8" listed, low heat, prefabricated, metal chimney system (listed by Underwriters Laboratories, Inc. or other approved laboratories) installed through the ceiling or wall. Before installing any woodburning unit to an existing chimney, take care that the chimney is sound. There should be no cracks or holes. Relining or rebuilding may be necessary to make the chimney safe and efficient and bring it into conformity with local codes. Under no conditions may more than one woodburning appliance be connected to one chimney. A proper chimney is most important for safe, satisfactory operation of any wood heating system.

Generally, the taller the chimney, the stronger and more dependable the draft. The chimney should also be kept warm to enhance the draft and protect against condensation of water vapor and smoke, which creates creosote. A build-up of creosote can reduce the draft and will become a potential fire hazard.

A chimney should extend at least three feet above a flat roof, or at least two feet above any part of the roof within 10 feet. Chimney tops should NEVER be near trees or other tall objects that might cause down-drafts.

## CHIMNEY CONNECTOR

There are two major types of stove pipe—insulated and not insulated. Insulated stove pipe (Class A) is actually prefabricated chimney. Several different types of pipe are available. Consult local building and fire codes to determine which types of pipe may be safely used. Ask your dealer about the availability of types of pipe which meet local codes.

The stove collar accepts only 8" pipe. The crimped end of the pipe fits into the collar to enable any distillates which may form in the chimney to fall back into the stove.

Generally speaking, heavy duty, single wall, non-insulated pipe (not less than 24 gauge) is used to connect the stove to a masonry or 'Class A' factory built, pre-fabricated chimney. This pipe can also be used horizontally as a connection between stoves and masonry chimneys, provided the length does not exceed three feet AND THE PIPE SLOPES UPWARD TOWARD THE CHIMNEY AT A RATE OF 1/4" to 1/2" PER FOOT. The slope required in the horizontal connection is to facilitate the draining of possible creosote deposits back into the stove. This pipe should be installed no closer than 18" to any unprotected wall or ceiling.

## OUTSIDE AIR SUPPLY

For proper installation, it is not mandatory that outside air for combustion be used. However, if local codes require it, an OUTSIDE AIR KIT is available from the dealer who sold you the stove.

The outside air inlet hose is a flexible tube which can be bent to take outside air in through the wall or up through the floor. The flexible tube will allow some adjustment over or around floor joists or plumbing. **DO NOT CHANGE THE STRUCTURAL INTEGRITY OF THE FLOOR.** This air hose must be kept open at all times to provide outside air for combustion.

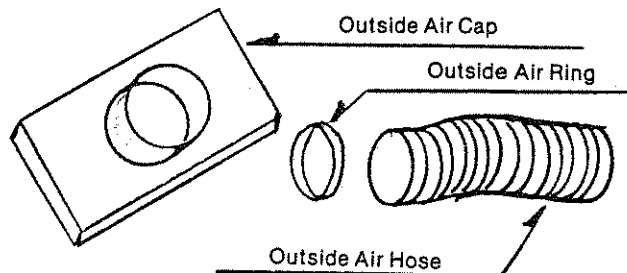

Fig. 6

## INSTALLATION

1. Set hearth and stove in location for marking holes in accordance with the dimensions listed on the label and Figures 5 and 6 of these instructions.
2. Mark the position for the hole in the ceiling and roof by using a string and plumb-bob.
3. Check that the intended location will not interfere with floor joists, ceiling joists, or rafters before proceeding further.
4. (If required) mark the positions of the hole for the outside air hose.
5. (If required) move the stove and, using a saber saw with a masonry blade, cut a 2 $\frac{3}{4}$ " hole for the outside air hose.
6. Cut a pilot hole in the ceiling.
7. Cut a 14 $\frac{1}{2}$ " square hole and frame in both sides of this hole in both ceiling and roof (FOR SAFE INSTALLATION HOLE MUST NOT BE SMALLER THAN 14 $\frac{1}{2}$ ").
8. Measure the distance from the ceiling to the top of any combustible material. If required, trim the top of the joist shield so that it will clear any combustible material when installed in step 11. Note that the joist shield may extend completely through the roof on some installations and may require trimming, only to allow the proper positioning and attachment of the roof flashing and storm collar. See Fig. 4.
9. Slide the stove back into position.
10. To start installing pipe, turn the first section of pipe upside down and slip the crimped edge of the pipe inside the stove flue.
11. Install the remaining lengths of pipe one on top of the other to the finished height of the chimney connector, and secure to each other. When approaching the ceiling, slip the ceiling trim plate and joist shield over the chimney so that after the chimney is extended through the ceiling, the ceiling trim plate can be secured to the ceiling. The joist shield rests on the ceiling trim plate but is not secured to it. CAUTION: Since the chimney section lengths vary, you will need to calculate where the joints will come to ensure that they do not come between the ceiling and the roof.
12. Slip the roof flashing down over the chimney and nail to the roof being careful to keep the pipe centered in the opening. NOTE: To meet the code, the chimney must extend above the roof at least three feet and two feet above any area of the roof within ten feet of the chimney.
13. (If required) attach the air intake tube adapter to the bottom of the air intake tube by snapping it into place. Install the outside air hose down through the hole cut in step 5. Place the outside air hose clamp over the top end of the outside air hose and install the hose to the air intake tube adapter. Tighten the outside air hose clamp.

14. Install the side ceramics by holding each carefully in place within the raised outline. Gently fold the tabs on the stove face around the ceramic tiles. Do the same with the door ceramic. REMEMBER, these ceramics are a clay product and must be handled carefully. THEY ARE FRAGILE.
15. On Jet-Air models, attach the blower motor. This motor is attached to the blower intake on the rear of the stove with four self-tapping screws. It is equipped with a three-prong (grounded) plug to prevent shock hazard. THIS PLUG SHOULD BE INSERTED DIRECTLY INTO A PROPERLY GROUNDED, THREE-PRONGED RECEPTACLE. DO NOT CUT OR REMOVE THE GROUNDING PRONG FROM THIS PLUG.

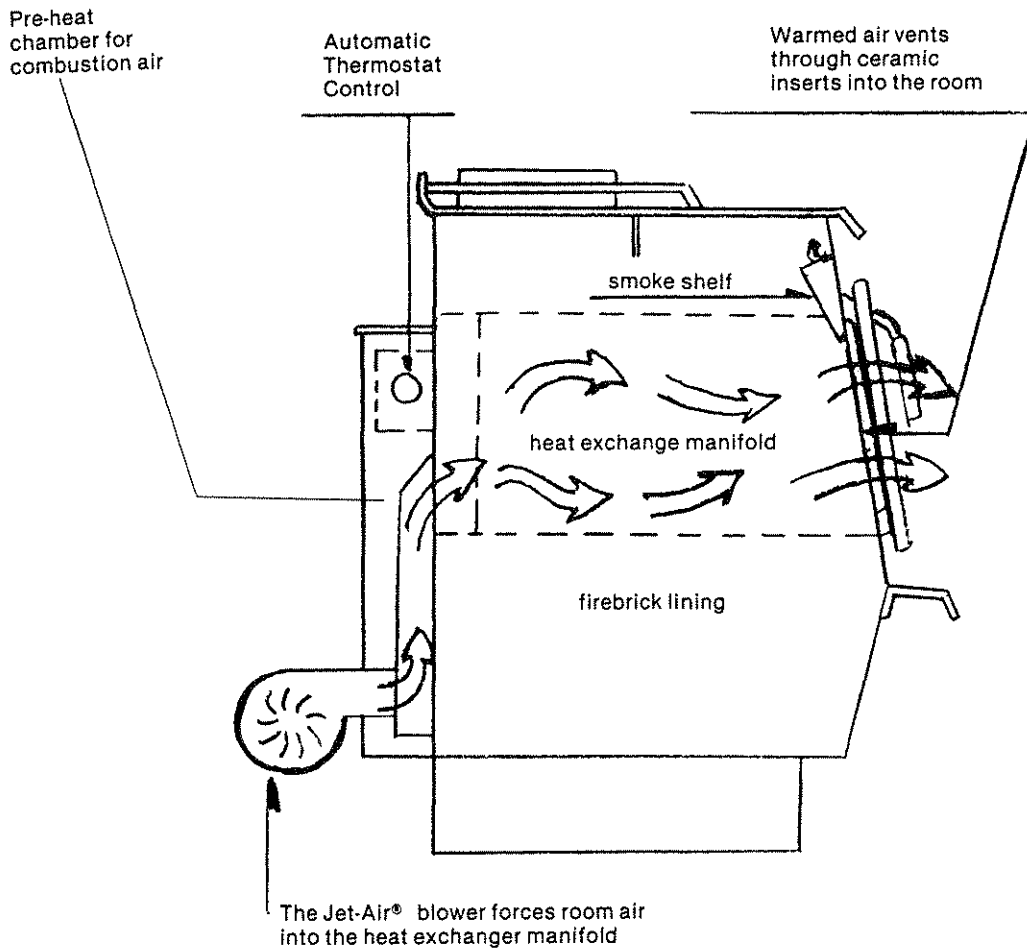

Fig. 7

## FUEL

Blaze King® woodstoves will burn just about anything. Therefore, it is tempting to burn materials which are inadvisable. Green softwoods burn slowly and with smoke. The soot and moist tar from this smoke sticks to the inside of the chimney. Moisture in green wood will release a great amount of vapor which will condense on the inside of the chimney. The use of dry wood will retard any excessive build up.

Do not burn trash, paper, pine branches or artificial fire logs. Such abuse may void the warranty.

## FLAMMABLE LIQUIDS

NEVER use gasoline, gasoline-type lantern fuel, kerosene, charcoal lighter fluid, or similar liquids to start or "freshen up" a fire in this stove. Keep all such liquids well away from the stove while it is in use.

THIS STOVE IS FOR USE WITH SOLIDS FUELS ONLY.

## THE FIRST FIRE

Set the thermostat to HIGH (fully counterclockwise).

Place two or three large balls of crumpled paper in the front of the firebox. Lay some small dry sticks or wood chips on top of the paper as kindling. Use enough to establish a good fire base. Lay one or two larger pieces of wood (small logs) on top of the kindling.

Light the paper and allow the fire to get a good start. Now close the door with the handles in the vertical position so that the latches set against the door flange. The door should stay in this position (open about 1") for about 10 minutes or until the larger pieces of wood get a good start. **DO NOT LEAVE THE STOVE UNATTENDED WITH THE DOOR OPEN ON THE LATCHES!!**

Now open the door and carefully add three or four good sized logs. More can be added if desired without increasing the heat output—the fire will just burn longer. Close the door tightly and set the thermostat to low (clockwise).

**NOTE:** As you heat up the stove for the first time, the paint will go through a curing process and it will give off an odor. To minimize this inconvenience, burn the stove at a low temperature setting for several hours. If the odor gets too unpleasant, you may have to open a door or window slightly until the odor dissipates.

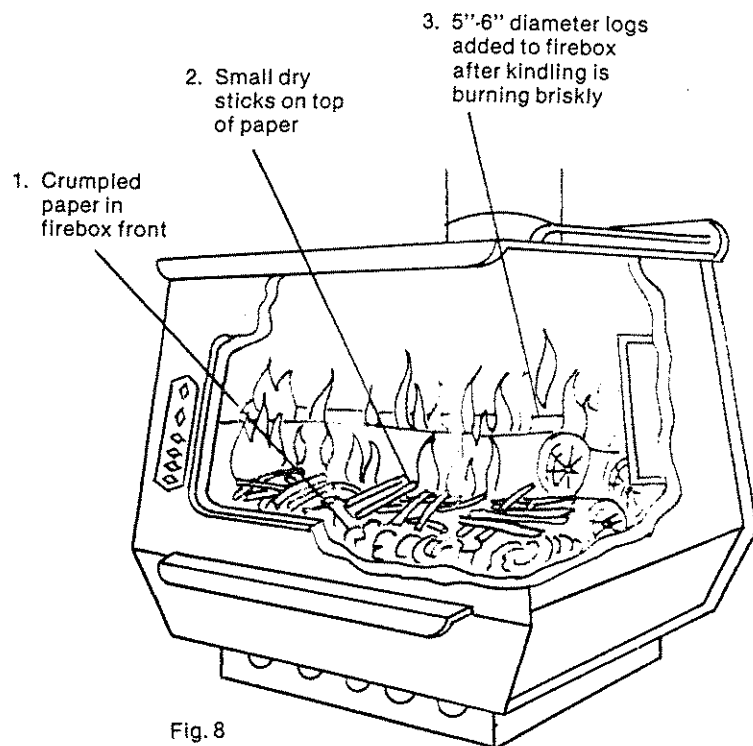

Fig. 8

Probably the least understood requirement in maintaining a good fire is that of establishing a good base of ash and coals. Many woodstove users hesitate to load enough wood to sustain a fire, but a good bed of hot coals will maintain a more even temperature as well as getting the new load of wood started easily.

## OPERATION

When you add fuel to the stove, open the door slightly (about 1") and then hold in that position for 10-30 seconds or until the fire livens up. Then open the door the rest of the way.

Seven or eight 5" or 6" diameter logs may burn for up to 14 hours. This will vary considerably with the variables of model of stove, type of wood, whether the wood is "seasoned," the thermostat setting, the position of the stove in the house, and how well the house is insulated. The stove can be fully loaded without increasing the heat output. The stove will simply burn longer.

**CAUTION**—After the fire has been allowed to liven up and the door closed, **DO NOT** open the door for at least 4-5 minutes. Hot gasses build up right after the door is closed and the addition of oxygen when the door opens will cause a rapid combustion, sending smoke, and possibly some flame, into the room.



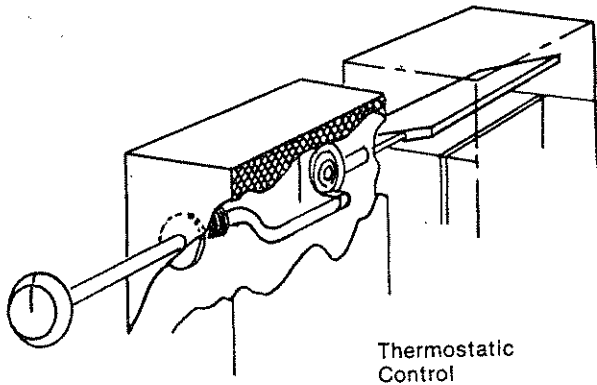

Fig. 9

Under normal operations, the thermostat should be set on low (clockwise), and at this setting the stove is capable of heating an average size home. Medium and high settings are only to be used for short intervals. **DO NOT LEAVE THE STOVE UNATTENDED ON THESE SETTINGS.** The thermostat is set at the factory and should not be tampered with. You may notice that the damper in the air intake duct is open even when set on low. This is normal. It will close down automatically after the fire is started.

If at some time it seems that the stove is not getting hot enough for the corresponding draft setting, check to see that something is not blocking the draft inlet inside the stove such as ashes or a piece of wood.

If the thermostat breaks, the damper will automatically close, thus preventing a runaway fire.

To convert the stove to an open fire, first turn the thermostat to LOW. Open the door slightly (about 1") and then hold in that position for 10-30 seconds or until the fire livens up. Next, remove the door (open to the vertical position and lift straight up) and replace it with the door screen.

**CAUTION:** Place the door on a noncombustible surface—it is very hot.

A grate is not needed when burning wood. When burning coal, however, the fire burns better if you use a grate or coal basket.

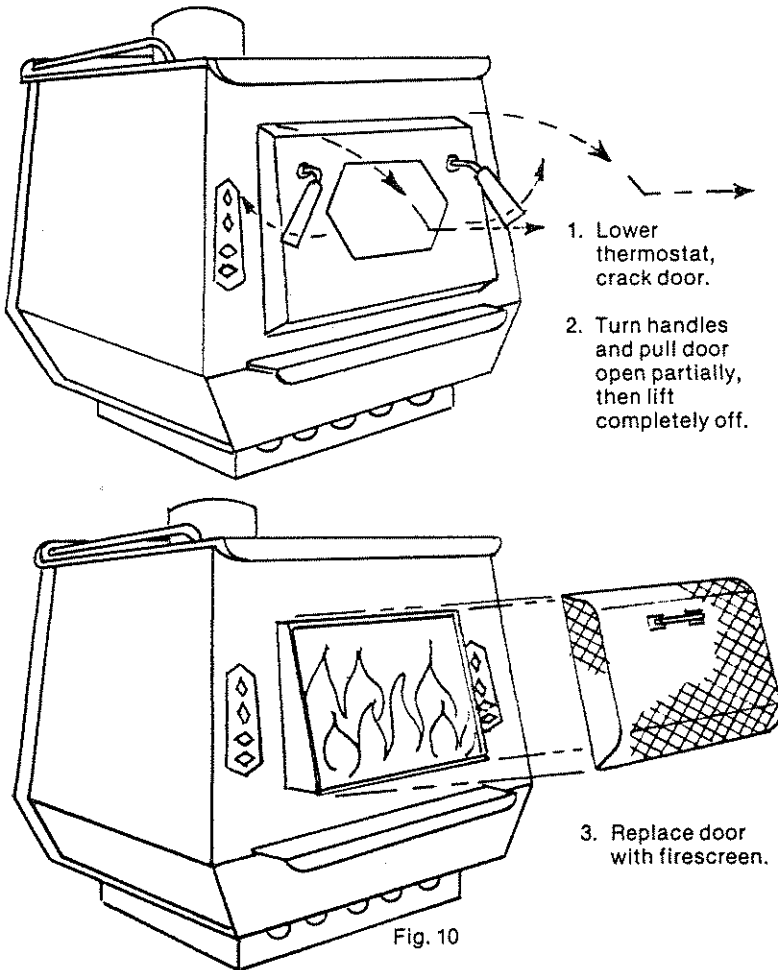

Fig. 10

The door with the glass window is installed the same way as the regular door. Set the hinge rods in the hinges with the door in the vertical position. Open or close as desired.

The basic design of the door will keep the glass from becoming clouded rapidly. However, after some amount of use the glass will have to be cleaned. After the door has been removed and allowed to cool, it can be cleaned with soap and water or a non-abrasive cleanser.

If the glass gets broken, your Blaze King® dealer can provide a replacement. After the door has been removed and allowed to cool, remove the screws and the retaining strips on the inside of the door. Retain these parts. Remove the broken glass. To install the braided gasket to the lower edge of the glass, fold the gasket so that it adheres to both sides of the lower edge of the glass. Insert the gasketed lower edge into the bottom channel. Attach the top retainer with the screws previously removed. Attach the right and left glass retainers.

## **ASH REMOVAL**

The ashes must be removed from the stove any time they start getting close to covering the draft inlet in the stove firebox. The frequency with which you need to empty the ashes depends on the type of fuel being used. Remove ashes only when they are cold so that hot coals are not dumped where they may start a fire.

Ashes should be placed in a metal container with a tight-fitting lid. The closed container of ashes should be placed on a noncombustible floor or on the ground, well away from all combustible materials, pending final disposal. If the ashes are disposed of by burial in soil or otherwise locally dispersed, they should be retained in the closed container until thoroughly cooled.

## **CREOSOTE—FORMATION AND NEED FOR REMOVAL**

When wood is burned slowly, it produces tar and other organic vapors, which combine with expelled moisture to form creosote. The creosote vapors condense in the relatively cool chimney flue of a slow-burning fire. As a result, creosote residue accumulates on the flue lining. When ignited this creosote makes an extremely hot fire. The chimney connector and chimney should be inspected at least twice monthly during the heating season to determine if a creosote build up has occurred.

If creosote has accumulated, it should be removed to reduce the risk of a chimney fire.

## **LUBRICATION**

Lubricate the fan motor bearings of Jet-Air models every six months with 10 to 20 drops of SAE 10W or 20W non-detergent oil (ML-type) or with electric motor oil.

**CAUTION:** Do NOT over-lubricate. The excess oil may damage the windings or electrical wiring on the motor.

## **PAINT**

If the black finish on the stove ever becomes blemished, you can repaint with high temperature paint available from your dealer. Do not paint the stove while it is HOT.

## **FURTHER INFORMATION**

For further information on using your wood stove safely, obtain a copy of the National Fire Protection Association publication, "Using Coal and Woodstoves Safely" NFPA #HS-10. The address is:

National Fire Protection Association  
Batterymarch Park  
Quincy, MA 02269

## **AUTHORIZED SERVICE REPRESENTATIVE**

Your local Blaze King® dealer is your authorized service representative. Should you have any problems with operation or maintenance of your Blaze King® stove, contact him as soon as possible. He will assist you in resolving any operation problems, provide replacement parts, and/or arrange warranty repairs as required. He will need information such as model, serial number, date of purchase, and a summary of the problem to accomplish the resolution of your problem. A list of some of the more common replacement parts is given below.

## REPLACEMENT PARTS

ITEM	PART NO.	
CERAMICS		
Blaze King	0114	orange, brown, blue, green, black
Blaze King, Jet Air	0115	orange, brown, blue, green, black
Blaze Princess	0116	orange, brown, blue, green, black
Blaze Princess, Jet Air	0117	orange, brown, blue, green, black
DOOR GASKET	0180	
DOOR HANDLES	0118	
DOOR SCREEN		
MOTOR	0112	
SPRAY PAINT (aerosol can)	0128	
THERMOSTAT KNOB	0102	
OUTSIDE AIR KIT		

**MANUFACTURED UNDER LICENSEE AGREEMENT**

**FROM: WOODCUTTERS MFG., INC.  
ROUTE 4, BOX 218  
WALLA WALLA, WA 99362**

**BY:**